

H&S

“ALL PURPOSE” Heavy Duty Manure Spreader

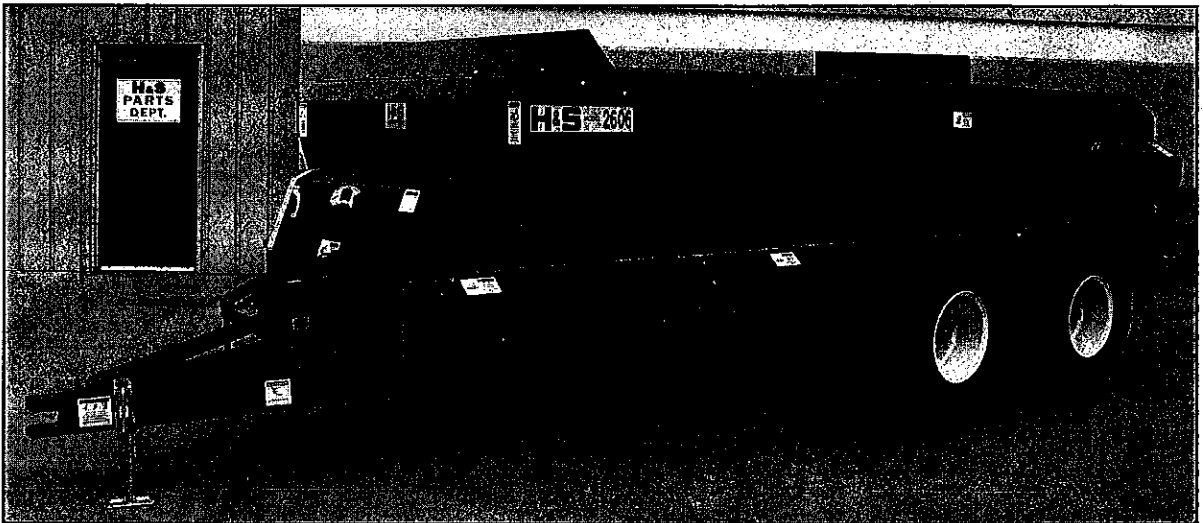

WARNING

READ AND UNDERSTAND THIS MANUAL
BEFORE OPERATING THIS EQUIPMENT.

UNSAFE OPERATION OR MAINTENANCE OF THIS EQUIPMENT CAN RESULT IN SERIOUS
INJURY OR DEATH.

MODELS 1506, 1806, 2206, 2606 & 3306

PARTS & OPERATOR'S INSTRUCTIONS

9-8-05

Manufactured By

H&S MANUFACTURING CO., INC.

P.O. BOX 768 • (715) 387-3414 FAX (715) 384-5463

MARSHFIELD, WISCONSIN 54449

H&S ALL PURPOSE SPREADERS PARTS AND OPERATORS MANUAL

CONTENTS

Warranty & Warranty Registration Card	1-2
Dealer Pre-Delivery & Delivery Checklist	3
Be Alert Symbol	5
Explanation of Safety Signs	6
Danger - Warning Signs	7-8
Warning - Owner Must Read and Understand	9
Operation - Attaching to Tractor - Loading	10-11-12
Spreading - Adjustments	13-14-15-16
Lubrication Guide	17-18-19
Decal Location & Identification	20-21
Instructions for Ordering Parts - About Improvements	22
Service Notes	23
Figure 1 - Box & Component Parts - Description	24-25
Figure 2 - Augers & Drive Assembly - Description	26-27
Figure 2 - Continued	28-29
Figure 3 - Shields - Sideshaft - Axle Assembly - Description	30-31
Figure 3 - Continued	32-33
Figure 4 - Beaters & Pan Assembly - Description	34-35
Figure 5 - Hydraulics - Description	36-37
Figure 6 - Outside Beater Gearbox - Description	38-39
Figure 7 - Inside Beater Gearbox - 1506-1806 - Description	40-41
Figure 7A - Inside Beater Gearbox - 2206-2606-3306 - Description	42-43
Figure 8 - Hydraulic Cylinder - Back Door - Description	44
Figure 9 - Hydraulic Cylinder - Clean-Out Door - Description	45
Figure 10 - PTO - 2004 & Prior Model Year Description	46
Figure 11 - PTO - 2005 & After Model Year Description	47
Figure 12 - Electric Control Box - Description	48
SPECIFICATIONS	INSIDE BACK COVER

WARRANTY

Mr. Owner: Before Operating—Read and Understand Operating and Safety Instructions

H&S Manufacturing Co., Inc. truly believes you have made a wise choice and a sound and lasting investment. Many years of development have made available these quality machines to assure you the performance and reliability you need. **We ask you to read the following agreement and warranty as this unit is subject to this warranty and agreement and no other.**

H&S MANUFACTURING CO., INC. WARRANTY

H&S Manufacturing Co., Inc. ("H&S") warrants this product to be free from defect in material and workmanship. Except as noted below, this warranty term is twelve (12) months from the date of delivery of the product to the original purchaser by an authorized H&S dealer. Under this warranty, H&S will repair or replace, at its option, any covered part which is found to be defective in material or workmanship during the applicable warranty term. In no case will the covered repair cost of a part or parts exceed the replacement cost of that part. Warranty service must be performed by H&S or a dealer authorized by H&S to sell and/or service the product involved, which will use only new or remanufactured parts or components furnished by H&S. This warranty includes approved parts and labor to fix the product but does not include, and the purchaser is responsible for, any service call and/or transportation of the product to and from the dealer's place of business, for any premium charged for overtime labor requested by the purchaser, and for any service work not directly related to any defect covered under this warranty. This warranty includes only those components of the product manufactured by H&S. Warranty for any component not manufactured by H&S including, but not limited to, engines, batteries, tires, rims, hydraulic motors, pumps, etc., are covered by the warranty, if any, provided separately by their respective manufacturers.

This warranty in all its parts, is extended solely to the original purchaser of the product, is terminated upon any subsequent transfer or sale from or by the original purchaser and extends no third party benefits or rights whatsoever.

The warranty term for any product used in any commercial, custom for hire or rental application, is limited to six (6) months from the date of delivery of the product to the original purchaser by an authorized H&S dealer.

Polybonded (polyethylene and plywood) panels utilized in H&S Manure Spreaders are warranted, to the original purchaser, to not wear through and the polyethylene overlay to not tear free of the plywood for the functional life to the spreader. This specific warranty on polybonded panels includes only replacement of any defective panel part without any allowance for labor beyond the terms of the general warranty (12 or 6 months), and is further limited to manure spreaders used to spread normal agricultural manure.

This warranty does not include: (1) Any product that has been altered or modified in ways not approved by H&S; (2) Depreciation or damage caused by normal wear, misuse, improper or insufficient maintenance, improper operation, accident or failure to follow the product Operator Manual recommendations and product decal recommendations; (3) Normal maintenance parts and service; (4) Repairs made with parts other than those available from H&S or performed by anyone other than H&S or a dealer authorized by H&S to sell and/or service the product involved.

To secure warranty service the purchaser must report the product defect to a dealer authorized by H&S to sell and/or service the product involved within the applicable warranty term together with evidence of the warranty start date and make the product available to that dealer within a reasonable period of time.

THERE ARE NO WARRANTIES WHICH EXTEND BEYOND THE DESCRIPTION ON THE FACE OF THIS WARRANTY. H&S and the companies affiliated with it makes no warranties, representations, or promises, express or implied, as to the quality or performance or freedom from defect of its products other than those set forth above and **NO IMPLIED WARRANTY OF MERCHANTABILITY, FITNESS OR FITNESS FOR A PARTICULAR PURPOSE IS MADE. IN NO EVENT WILL THE DEALER, H&S OR ANY COMPANY AFFILIATED WITH H&S BE LIABLE FOR INCIDENTAL OR CONSEQUENTIAL DAMAGES.** The **ONLY REMEDY** the purchaser has in connection with the breach of performance of any warranty on H&S products are those set forth above.

The selling dealer has no authority to make any representation or promise on behalf of H&S, or to modify the terms or limitations of this warranty in any way.

2/16/2004

**FILL OUT AND MAIL
IMMEDIATELY TO MAKE
WARRANTY EFFECTIVE**



WARRANTY REGISTRATION

Date of Purchase _____

Purchaser _____ Address _____

City _____ State _____ Zip _____

Product _____ Model # _____ Serial # _____

Dealer _____ Address _____

City _____ State _____ Zip _____

Signature of original buyer

IMPORTANT!

Tear on dotted line, provide the information requested on the card. The H&S Warranty is valid **“only”** after this card is received and recorded at H&S Mfg. Co. Mail at once. No postage is required in the U.S.A.

This Is Your Warranty Card
Please Fill Out
And Mail Immediately



NO POSTAGE
NECESSARY
IF MAILED
IN THE
UNITED STATES

BUSINESS REPLY MAIL
FIRST CLASS MAIL Permit No. 195 Marshfield, WI 54449

POSTAGE WILL BE PAID BY ADDRESSEE

H&S Manufacturing Co., Inc.
PO Box 768
Marshfield WI 54449-9963



AFTER COMPLETION, DEALER SHOULD REMOVE AND RETAIN FOR RECORDS

**H&S
DEALER PRE-DELIVERY CHECK LIST**

After the Manure Spreader has been completely set-up, check to be certain it is in correct running order before delivering to the customer. The following is a list of points to inspect. Check off each item as you have made the proper adjustments and found the item operating satisfactorily.

- PTO Shields turn freely.
- All Shields and Guards are in place and fastened.
- All grease fittings have been lubricated and gearboxes filled to proper level – See lubrication guide in this manual.
- All mechanisms are operating trouble free.
- All Roller Chains are at proper tension.
- All bolts and fasteners are tight.
- All decals are in place and legible.

(Dealer's Name)

Model Number

Serial Number

(Signature of Pre-Delivery Inspector)

(Inspection Date)

DEALER DELIVERY CHECK LIST

This check list that follows is an important reminder of valuable information that should be passed on to the customer at the time this Manure Spreader is delivered.

Check off each item as you explain it to the customer.

This pre-delivery check list, when properly filled out and signed assures the customer that the pre-delivery service was satisfactorily performed.

- Explain to the customer that the pre-delivery inspection was made.
- Explain to the customer all the safety precautions they must exercise when operating this unit.
- Explain recommended loads for different types of materials.
- Explain to customer that regular lubrication is required for proper operation and long life of machine. Show customer the lubrication section of Owner's Manual.
- Give the customer Owner's Manual and make sure he reads and understands all operating and service instructions.
- Record Serial Number on Page 22 of this Manual.
- Have customer sign a completed "Warranty Registration," and mail it promptly.

Date Delivered _____

Dealer's Name _____

By _____

Signature of Original Buyer

Note: Warranty is not valid until warranty card is completed and returned to H&S Mfg. Co., Inc.





**BE
ALERT!** **YOUR SAFETY
IS INVOLVED.**

THIS SYMBOL IS USED THROUGHOUT THIS BOOK WHENEVER YOUR PERSONAL SAFETY IS INVOLVED. TAKE TIME TO BE CAREFUL. REMEMBER: THE CAREFUL OPERATOR IS THE BEST OPERATOR. MOST ACCIDENTS ARE CAUSED BY HUMAN ERROR. CERTAIN PRECAUTIONS MUST BE OBSERVED TO PREVENT THE POSSIBILITY OF INJURY OR DAMAGE.

TRACTORS

This OPERATORS manual uses the term "Tractor" when identifying the power source.

H&S MANUFACTURING CO. INC.

RECOGNIZE SAFETY INFORMATION

This is the safety-alert symbol. When you see this symbol on your machine or in this manual, be alert to the potential for personal injury.

Follow recommended precautions and safe operating practices.



UNDERSTAND SIGNAL WORDS

A signal word—DANGER, WARNING, or CAUTION—is used with the safety-alert symbol. DANGER identifies the most serious hazards.

Safety signs with signal word DANGER or WARNING are typically near specific hazards.

General precautions are listed on CAUTION safety signs.



WARNING



CAUTION



FOLLOW SAFETY INSTRUCTIONS

Carefully read all safety messages in this manual, and all safety signs on your machine. Follow all recommended precautions and safe operating procedures.

Keep signs in good condition. Immediately replace any missing or damaged signs.



! WARNING

DO NOT GO NEAR LEAKS

- High pressure oil easily punctures skin causing serious injury, gangrene or death.
- If injured, seek emergency medical help. Immediate surgery is required to remove oil.
- Do not use finger or skin to check for leaks.
- Lower load or relieve hydraulic pressure before loosening fittings.

11599

! WARNING

HELP AVOID INJURY

- READ & UNDERSTAND THE OPERATORS MANUAL PROVIDED WITH THIS MACHINE. IF MISPLACED CALL H & S MANUFACTURING AT 715-367-3414 WITH MODEL AND SERIAL NUMBER.
- UNDERSTAND ALL SAFETY WARNINGS AND FUNCTION OF CONTROLS.
- KEEP SAFETY DEVICES IN PLACE AND WORKING.
- KEEP YOURSELF AND OTHERS WELL CLEAR OF MOVING PARTS.
- DISCONNECT ALL POWER BEFORE SERVICING OR CLEANING THIS MACHINE.
- DO NOT EXCEED 20 MPH

72203

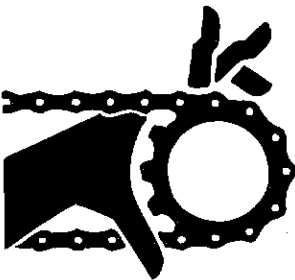

! WARNING

DO NOT OPERATE THIS EQUIPMENT IF THIS DECAL IS EXPOSED. REPLACE SAFETY SHIELDS.

1494A

! DANGER



STAY CLEAR OF BEATER IF TRACTOR OR PTO IS RUNNING. MANURE AND FOREIGN OBJECTS CAN BE THROWN CONSIDERABLE DISTANCES.

FAILURE TO HEED THIS WARNING MAY RESULT IN PERSONAL INJURY OR DEATH.

KEEP CLOTHING, YOURSELF AND OTHERS WELL CLEAR.

9894



! DANGER

KEEP OUT

DISENGAGE ALL POWER AND SHUT OFF TRACTOR ENGINE BEFORE ATTEMPTING TO ENTER OR CLEAN SPREADER

FAILURE TO HEED THIS WARNING MAY RESULT IN PERSONAL INJURY OR DEATH

111593B



! WARNING

DO NOT OPERATE THIS EQUIPMENT IF THIS DECAL IS EXPOSED. REPLACE SAFETY SHIELDS.

71494A

! DANGER



ROTATING DRIVELINE CONTACT CAN CAUSE DEATH KEEP AWAY!

DO NOT OPERATE WITHOUT-

- ALL DRIVELINE, TRACTOR AND EQUIPMENT SHIELDS IN PLACE.
- DRIVELINES SECURELY ATTACHED AT BOTH ENDS.
- DRIVELINE SHIELDS THAT TURN FREELY ON DRIVELINE.

1494L



! WARNING

DO NOT REMOVE SHIELDS

ROTATING PARTS INSIDE

12794

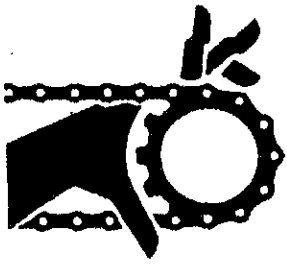

WARNING
DO NOT REMOVE SHIELDS
MOVING PARTS INSIDE

1494B

DANGER



NEVER ALLOW RIDERS ON THIS MACHINE

9194B

WARNING



**DO NOT REMOVE SHIELDS
MOVING PARTS INSIDE**

1494K

DANGER



NO STEP-STAY CLEAR

9194A

DANGER



ROTATING DRIVELINE CONTACT CAN CAUSE DEATH

5096B

WARNING



CRUSHING HAZARD
TO PREVENT SERIOUS INJURY OR DEATH:
KEEP HANDS AND BODY OUT OF HITCH AREA WHEN ATTACHING TOWING VEHICLE.
KEEP BODY CLEAR OF CRUSH POINT BETWEEN TOWING VEHICLE AND LOAD.
KEEP FEET AND LEGS CLEAR FROM UNDER TONGUE AREA IN CASE OF POSSIBLE JACK FAILURE.

62602

WARNING

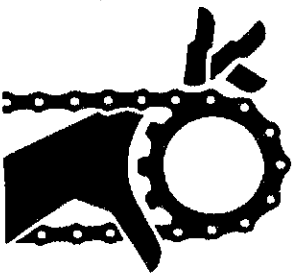

DO NOT CLEAN OR WORK ON THIS MACHINE WITHOUT FIRST DISENGAGING POWER AND SHUTTING OFF TRACTOR ENGINE.

1494J

DANGER



**STAY CLEAR OF BEATER IF TRACTOR OR PTO IS RUNNING
BEATER SHUT OFF COULD ACCIDENTALLY BE ENGAGED**
FAILURE TO HEED THIS WARNING MAY RESULT IN PERSONAL INJURY OR DEATH
KEEP CLOTHING, YOURSELF AND OTHERS WELL CLEAR

H&S "ALL PURPOSE" MANURE SPREADERS



WARNING

TO PREVENT SERIOUS INJURY OR DEATH

BEFORE YOU ATTEMPT TO OPERATE THIS EQUIPMENT, READ AND STUDY THE FOLLOWING INFORMATION. IN ADDITION, MAKE SURE THAT EVERY INDIVIDUAL WHO OPERATES OR WORKS WITH THIS EQUIPMENT, WHETHER FAMILY MEMBER OR EMPLOYEE, IS FAMILIAR WITH THESE SAFETY PRECAUTIONS.

KNOW HOW TO STOP UNLOADING MECHANISM BEFORE STARTING IT.

If the machine becomes clogged, disengage the power takeoff, stop the tractor engine and allow all mechanisms to stop before cleaning or working on the machine.

Never allow riders in or on the machine.

DO NOT get off the tractor while the spreader is in operation.

DO NOT attempt to perform maintenance or repair with tractor running and PTO and hydraulics hooked up.

DO NOT step up on machine at any time.

NEVER manually feed material into the beaters.

DO NOT allow minors to operate or be near the machine.

DO NOT ALLOW PERSONNEL OTHER THAN THE QUALIFIED OPERATOR NEAR THE MACHINE.

Before starting tractor, be sure PTO shields turn freely and PTO is securely locked to tractor.

DO NOT clean, adjust, or lubricate the machine when any part is in operation.

Keep hands, feet, and clothing away from beaters when they are revolving.

Loose or floppy clothing should not be worn by the operator.

Be sure the machine is clear of people, tools, and other objects before engaging PTO or hydraulics.

DO NOT step over power take off shaft. Stay clear of PTO at all times.

NEVER start manure spreader until all guards and safety shields are secured in place.

NEVER hook up 1000 RPM tractor to the spreader unless spreader is equipped for 1000 RPM.

STAY CLEAR of hydraulic fittings, they may be under extreme pressure.

When transporting on the highway, regularly clean the reflective tape and SMV decal at the rear of the spreader.

H&S Mfg. Co. always takes the operator and his safety into consideration and guards exposed moving parts for his protection. However, some areas cannot be guarded or shielded in order to assure proper operation. In addition, the operators manual and decals on the machine itself warn you of further danger and should be read and observed closely.

Study The Above Safety Rules

ATTENTION - BE ALERT - YOUR SAFETY IS INVOLVED

OPERATION

1. Check for proper assembly and adjustment and make sure that all bolts are tightened. Securely retighten after a few hours of operation, as bolts can loosen up on new machinery. Check wheel bolts upon delivery and periodically thereafter. Wheel bolts should be tightened at 85-95 ft./lbs. of torque.
2. Check the tires and inflate to the recommended pressure (11:00 x 22.5 tires to 40-60 pounds, 16.5 x 16.1 tires to 35-40 pounds).
3. Adjust the tractor hitch and attach the spreader to the tractor as described in the following sections.
4. Connect PTO from spreader to the tractor as described in the following sections.
5. Connect hydraulic hoses which operate augers from the spreader to a double acting valve on the tractor.
6. Connect hydraulic hoses which control rear gates from the spreader to a double acting valve on the tractor.
7. Connect electric auger speed control box to tractor power source, attach to a convenient place on the tractor.
8. Lubricate the machine completely and check the oil level of both gearboxes.
9. Before loading spreader, run machine for several minutes to make sure that the spreader is lubricated and operating properly.

TRACTOR HITCH

The hitch of the spreader is designed for a standardized tractor hitch. Adjust the drawbar so that it is 13 to 17 inches above the ground. Extend or shorten it so that the horizontal distance from the end of the tractor power take-off shaft to the center of the hitch pin hole is 14 inches, as shown in drawing. Use an adapter plate, if necessary, to secure the proper distance. An improperly located hitch point may cause damage to the universal joints of the power takeoff. Secure the drawbar so that the hitch pin hole is directly below the power drive line.

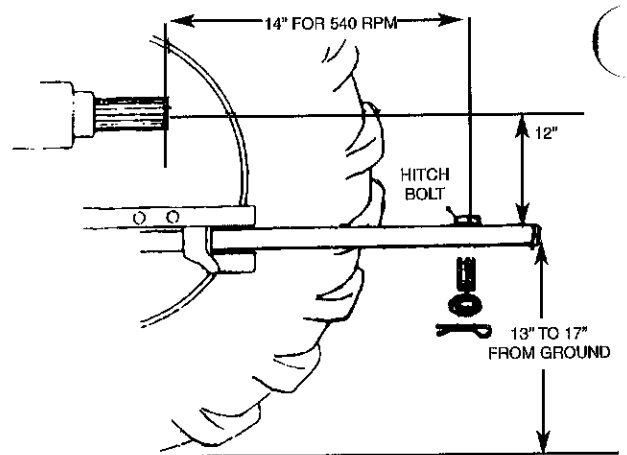
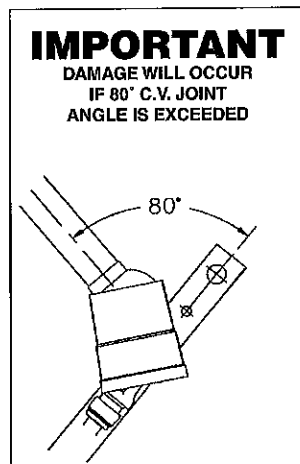

If this implement is attached to a tractor with a clevis hitch (hammer-strap) style drawbar, the hammer-strap must be removed to prevent damage to the IID guarding and the IID telescoping members. [See Figure 1]

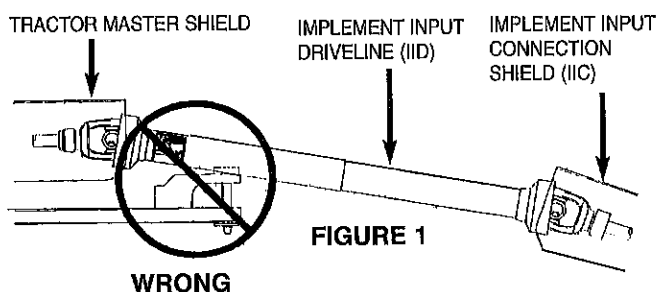

If this implement is attached to a tractor with an offset in the drawbar, be certain it is in the down position to prevent damage to the IID guarding and the IID telescoping members. [See Figure 2]

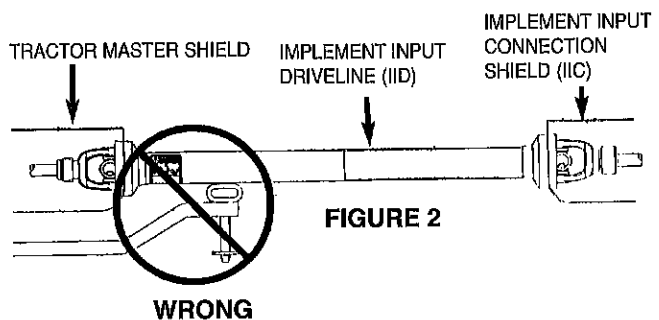

OPERATION *(Continued)*

ATTACHING TO THE TRACTOR

1. Fasten the spreader hitch to the drawbar with a **hitch pin that cannot bounce out**. Use 1" diameter hitch pin to pull spreader.
2. Remove the weight from the jack (jack is not to be used when spreader is loaded). Remove jack from pipe mount and place on convenient storage mount located on the left side of the spreader near front of spreader. This allows protection of jack from tractor tires during turns.
3. Slide spring loaded locking collar on PTO yoke rearward, and slide yoke onto the tractor PTO shaft. Release spring loaded collar. Be sure the pins fall into the groove of the tractor PTO shaft and collar snaps forward into locking position. **CAUTION:** Do not use a steel hammer to aid in joining PTO parts.

Be certain to disconnect all sources of power before servicing. Keep pant cuffs and other loose clothing away from all chain and gear drives as well as the other moving parts. Keep off the equipment when in use, and keep all safety shields in place. Do not attempt to clean, grease or lubricate while the machine is running. Never allow riders in or on the machine.

NOTE: Lift jack should not be used to support spreader during loading procedures.

SCRAPER STORAGE
JACK STORAGE POSITION

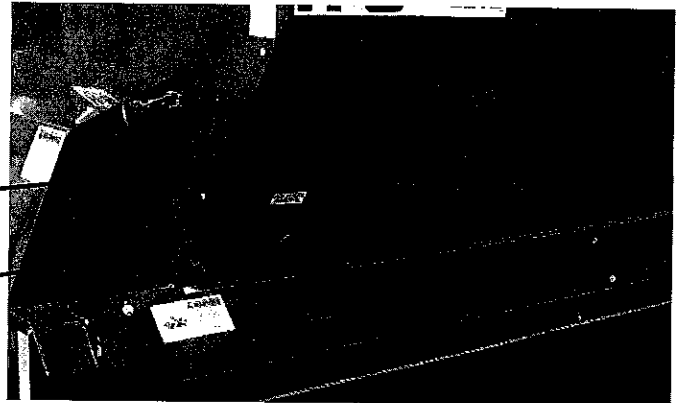

LOADING THE SPREADER

Although your spreader is designed and built to handle a wide range of manures, many potential problems can be avoided when manure is spread if the following guidelines are established and met.

NOTE: TO PREVENT DAMAGE TO AUGERS, BEATERS AND DRIVELINE, FOREIGN OBJECTS (STONES, HEAVY TIMBER, METAL, OR LARGE FROZEN CHUNKS OF MANURE) SHOULD NEVER BE PUT INTO THE SPREADER.

1. Before operation, especially in winter or freezing temperatures, make sure the augers and beaters are free to rotate, and the rear gate moves freely up and down.
2. Be sure rear gate and clean out door are closed before loading.
3. When loading pen-packed manure into the spreader with a loader bucket, shake the bucket to break up large chunks of manure. Material will spread more easily and efficiently.
4. Never excessively heap pen-packed or hard manure onto the spreader completely from front to rear.
5. Liquid manure or manure that flows will self-level allowing spreader to be filled to the top.

OPERATION (Continued)

UNLOADING AND SPREADING

To spread a wide variety of manure types and prevent unnecessary stress on the driveline components, observe the following guidelines for each type of manure.

Liquid or Semi-Solid Manure (self-leveling).

1. Engage tractor PTO at as low an RPM as possible. Slowly throttle tractor up to bring PTO up to 540 RPM.
2. Select desired ground speed and open discharge gate slowly to begin spreading.
3. Engage tractor hydraulics to operate augers.
4. To attain the desired coverage, adjust height of rear gate, speed of augers, and/or ground speed.

DRY, PEN-PACKED, OR MANURE CONTAINING LONG STRAW OR HAY.

1. Engage tractor PTO at as low an RPM as possible. Slowly throttle tractor up to bring PTO up to 540 RPM.
2. Select desired ground speed and open rear gate **completely** to begin spreading.
3. Engage appropriate lever of tractor hydraulics to operate augers. Begin unloading with augers at slow speed.
4. To achieve the desired coverage, adjust the speed of main augers and/or ground speed.

NOTE: IF IT BECOMES NECESSARY TO REVERSE AUGERS, ENGAGE TRACTOR HYDRAULICS SLOWLY.

OPERATION IN FREEZING WEATHER

1. Always allow spreader to empty completely.
2. Disengage tractor PTO and hydraulics.
3. Shut off tractor and remove ignition key.
4. Allow all movement to stop before attempting to clean spreader.
5. Scrape any remaining manure from inside and rear of spreader. Clean all manure from rear pan, end of auger housings, and beaters.
6. Operate main augers to clean any remaining manure from inside spreader.
7. Run rear gate up and down to sufficiently clean gate track.
8. After following steps 3, 4 and 5, again check rear pan and beater area to be sure it is clean of all manure.
9. After hauling liquid or semi solid manure, place a small amount of straw in each auger housing at the front of the spreader and operate spreader. This will wipe out excess liquid and help prevent freeze up of spreader.
10. Close clean out door at rear of spreader.
11. Park spreader with rear gate approximately halfway open.

NOTE: BEFORE LOADING SPREADER NEXT TIME, BE SURE AUGERS AND BEATERS ARE FREE TO ROTATE AND REAR DISCHARGE GATE MOVES FREELY UP AND DOWN.

ADJUSTMENTS

FAILURE TO FOLLOW THE RECOMMENDED ADJUSTMENTS WILL VOID WARRANTY

⚠ WARNING

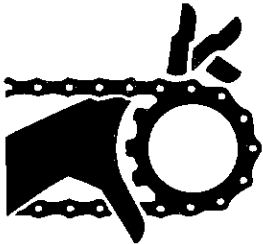

DO NOT CLEAN OR WORK ON THIS MACHINE WITHOUT FIRST DISENGAGING POWER AND SHUTTING OFF TRACTOR ENGINE.

AUGER DRIVE PRIMARY DRIVE CHAIN #60

Check adjustment on primary drive chain after first 5-6 loads. (This should allow for a sufficient wear-in period). Adjust chain by loosening nut (A). Then tighten nut (B) until there is 1/8" deflection at center of chain. Retighten nut (A). Check adjustment periodically to insure proper tension at all times. Overtightening or too loose of a chain will result in excessive wear on chain and sprockets.

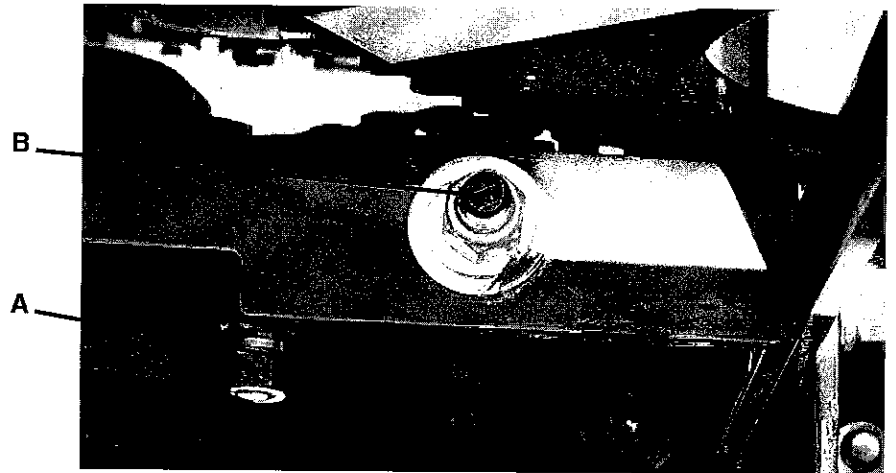

FINAL DRIVE CHAINS #80 (#100 on Model 3306)

Periodically check adjustment on final auger drive chains. Left and right hand augers each have their own tighteners. To tighten right hand drive chain, turn out (A) clockwise until there is 1/8" to 1/4" deflection at center of chain. Left hand auger drive chain is adjusted by turning nut (B) on tightener bolt clockwise until desired tension is reached.

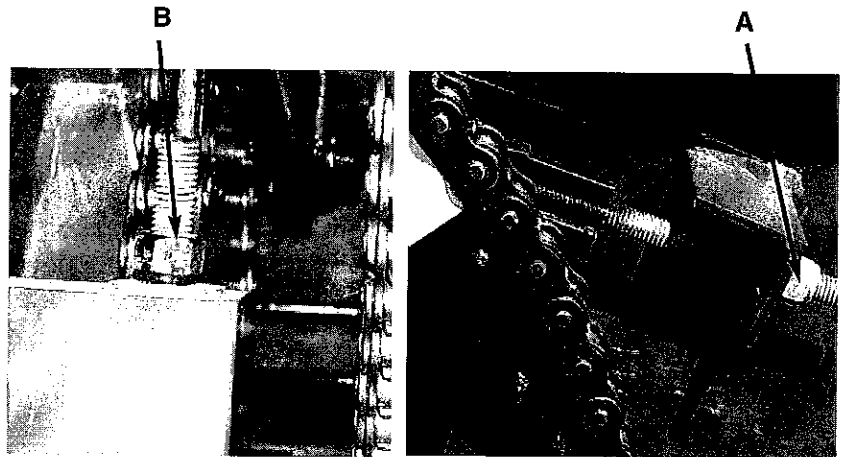

SIDE SHAFT DRIVE CHAIN #80

Check adjustment of side shaft drive chain after first 5-6 loads. (This should allow for sufficient wear-in period). To adjust front drive chain, loosen bolt A. Tighten nut B until there is 1/2" deflection at center of chain. Retighten bolt A. Check adjustment periodically to insure proper adjustment at all times. Overtightening or too loose of a chain will result in excessive wear on the bearings, chain, and sprockets.

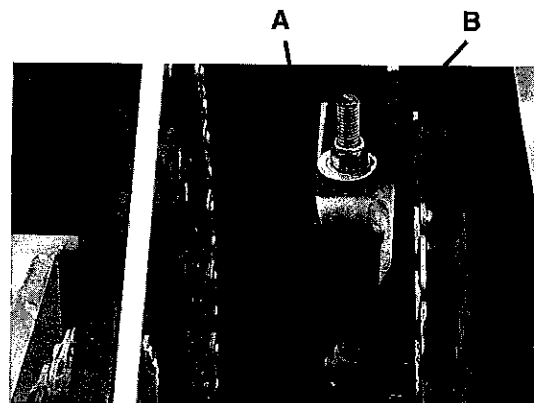

NOTE: Periodically lubricate roller chains with a light machine oil.

INTERNAL BEATER DRIVE CHAIN #80

To adjust internal beater drive chain, slightly loosen bolt A. Using a hammer and a blunt punch, slide sprocket and bolt in adjustment slot against roller chain. There should be 1/4" deflection at center of chain for proper adjustment. Retighten bolt A. Periodically check adjustment to insure proper tension at all times.

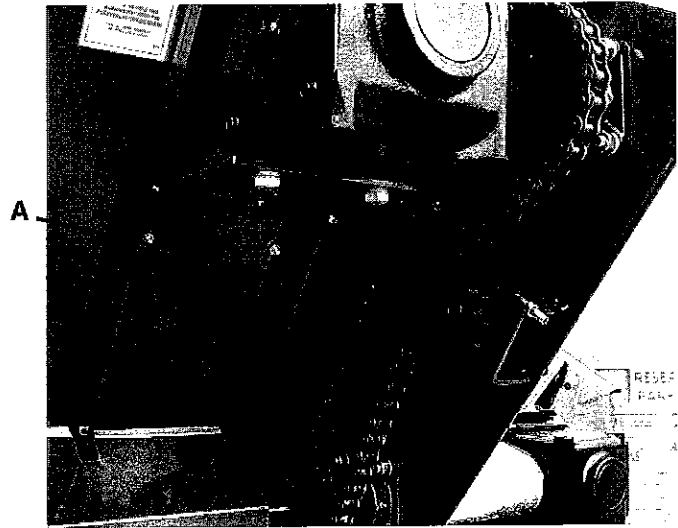

! DANGER



**ROTATING DRIVELINE CONTACT CAN CAUSE DEATH
KEEP AWAY!
DO NOT OPERATE WITHOUT-**

- ALL DRIVELINE, TRACTOR AND EQUIPMENT SHIELDS IN PLACE.
- DRIVELINES SECURELY ATTACHED AT BOTH ENDS.
- DRIVELINE SHIELDS THAT TURN FREELY ON DRIVELINE.

**SHEAR BOLT
NUT MUST FACE FORWARD**

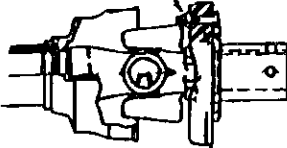

**540 RPM = 5/16 x 1-1/2 GR 8
1000 RPM = 5/16 x 1-1/2 GR 2**

SHEAR BOLTS

Both beaters at the rear of the spreader are protected by one shear bolt located in the PTO at the front of the spreader. Four spare shear bolts are provided. Shearing of shear bolt is normally due to large frozen chunks of manure, foreign objects (rocks, chunks of wood, etc.) in the manure, running augers too fast when unloading long straw and pen-packed material, or STARTING THE SPREADER PTO TOO QUICKLY WITH HIGH TRACTOR RPM'S. Always determine the reason for shearing bolt and eliminate problem before replacing shear bolt. Always use proper shear bolt (5/16-18 x 1-1/2" GR.8) for replacement when spreader is being operated at 540 RPM. Use shear bolt (5/16-18 x 1-1/2" GR.2) when spreader is being operated at 1000 RPM.

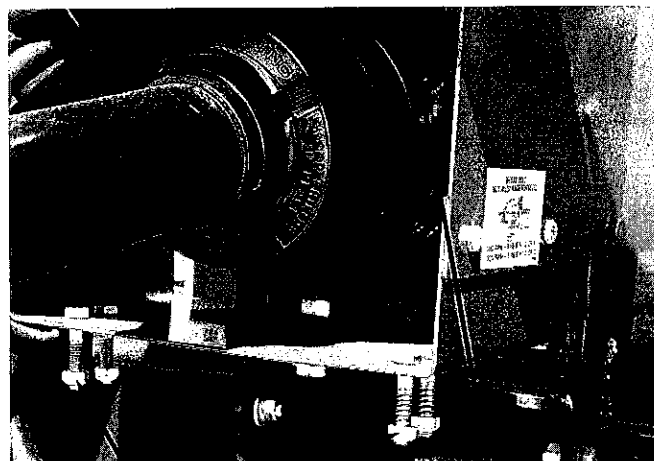

SPARE SHEAR BOLTS

SHEAR BOLT

ALL PURPOSE SPREADER, CLEAN OUT DOOR

The clean out door hydraulic cylinder is equipped with a shut off valve. This valve allows the user to lock the clean out door in the open or closed position for flexible operation.

VALVE OPEN POSITION

During normal operation, the valve is open. When the rear gate is to be opened, the clean out door will close first. When closing the rear gate, the clean out door will open first.

VALVE CLOSED POSITION

For liquid manure hauling, close the valve when the clean out door is closed. The clean out door will remain closed when the rear gate is operated.

For grain hauling, close the valve when the clean out door is open. The clean out door will remain open when the rear gate is operated.

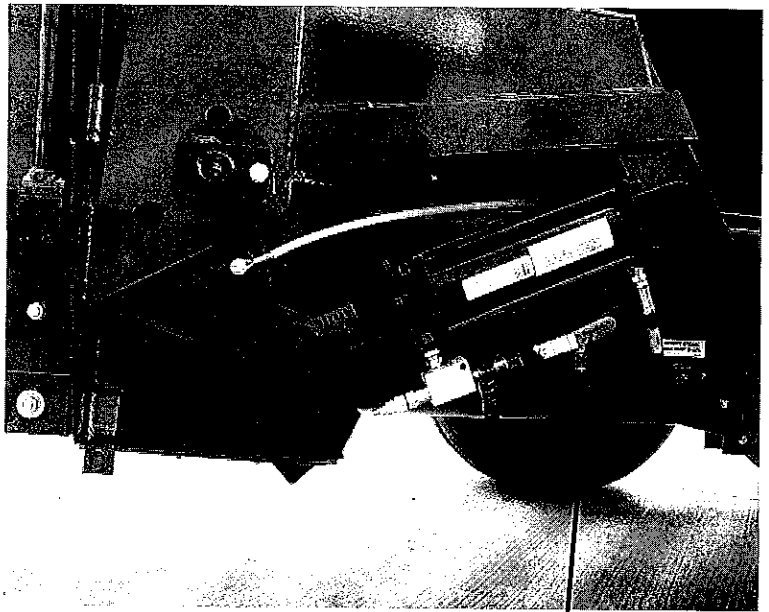

SHUT OFF VALVE

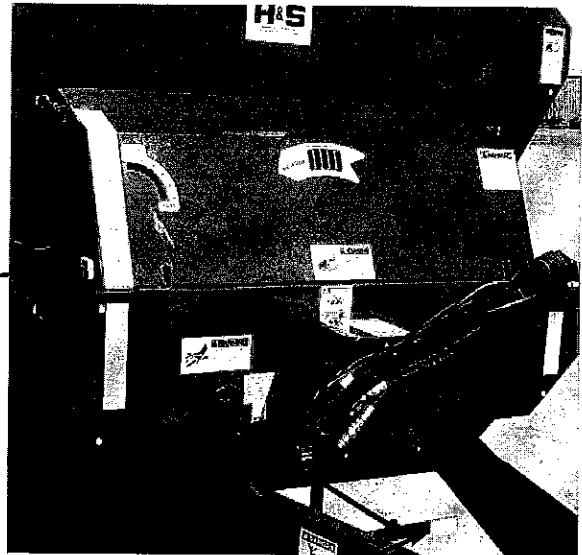

REAR DOOR INDICATOR

CLEAN OUT DOOR INDICATOR



! DANGER

STAY CLEAR OF BEATER IF
TRACTOR OR PTO IS RUNNING
BEATER SHUT OFF COULD
ACCIDENTALLY BE ENGAGED
FAILURE TO HEED THIS
WARNING MAY RESULT IN
PERSONAL INJURY OR DEATH
KEEP CLOTHING, YOURSELF
AND OTHERS WELL CLEAR

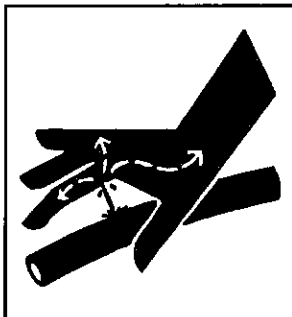

WARNING

DO NOT GO NEAR LEAKS

- High pressure oil easily punctures skin causing serious injury, gangrene or death.
- If injured, seek emergency medical help. Immediate surgery is required to remove oil.
- Do not use finger or skin to check for leaks.
- Lower load or relieve hydraulic pressure before loosening fittings.

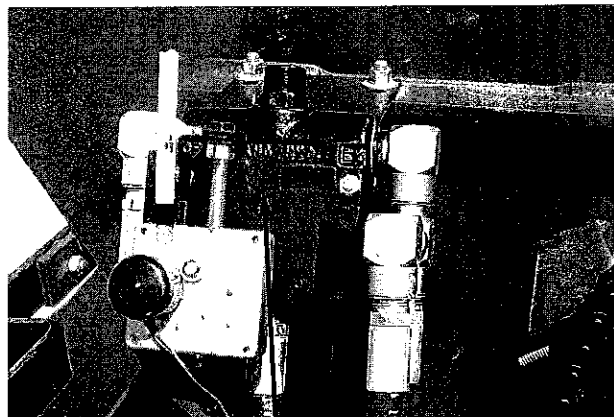

SPEED CONTROL VALVE

AUGERS

The main augers are hydraulically driven to offer a wide range of unloading speeds. Auger speed is controlled by utilizing the cab-mounted electric control. By moving the indicator from slower to faster as marked, the auger speed can be varied from zero to 13 RPM, depending on the tractor hydraulic system. A tractor hydraulic system with 16 gallons per minute flow, and 2200 pounds per inch pressure, will operate the spreader at maximum speed and performance. A system with less pressure will operate spreader efficiently, depending on type of material and the weight of the load. The auger driven mechanism is protected by a preset relief valve. Overriding relief valve is caused by too heavy of a load, feeding long material into the beaters too fast, or foreign object lodged in augers.



ELECTRIC AUGER SPEED CONTROL



NOTE: In some photographs within this operators manual, the shields have been removed or opened for clarification purposes only. **NEVER OPERATE SPREADER WITH GUARDS OR SHIELDS REMOVED.**

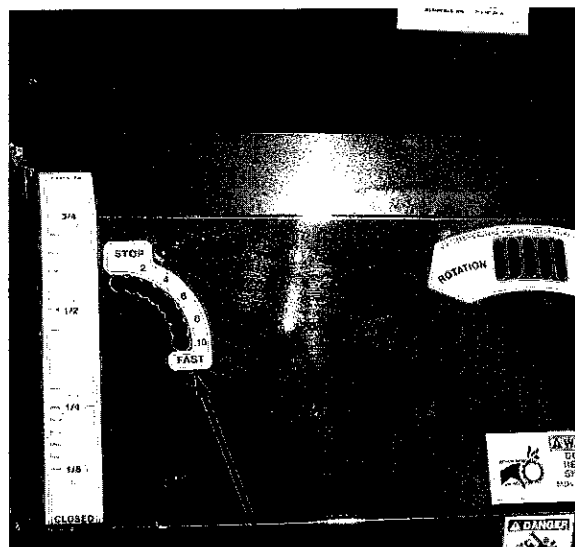

AUGER SPEED INDICATOR

ADJUSTING WHEEL HUBS

To adjust wheel hubs, tighten the castellated nut on the spindle to the point where there is no end-play and a slight drag on the bearings. Replace the cotter key with a new one of the correct size.

LUBRICATION GUIDE

PTO ASSEMBLY – Care must be taken to keep the male and female driving elements well lubricated and free sliding. Failure to observe this precaution will result in excessive pressure being required to collapse or extend the assembly while subject to operating torque. This excessive force may damage or displace the jackshaft bearings. **DO NOT** lubricate the shield surfaces. The shield surfaces must be kept dry, as dirt accumulation on them will quickly cause these units to bind and not rotate. Care should also be taken to be certain that the rotating integral shields are not dented or damaged, as this also will result in excessive force being applied against the jackshaft. Damaged shields also cause obvious difficulties when installing the assembly. If at any time the shields do not turn freely, they should be checked to determine the cause, and repaired or cleaned. To avoid damage to the main drive bearings, avoid turning sharp corners while PTO is running. Start and Stop PTO slowly to avoid damage to the drive train.

LUBRICATION REQUIREMENTS

<u>INTERVAL</u>	<u>LOCATION</u>	<u>AMOUNT</u>
8 HRS.*	CROSS & BEARINGS	1-PUMP
8 HRS.	TELESCOPING MEMBERS	4-8 PUMPS
8 HRS.	C.V. BALL & SOCKET	1-2 PUMPS
24 HRS.	C.V. CENTER HOUSING	4-PUMPS

IMPORTANT
DAMAGE WILL OCCUR
IF 80° C.V. JOINT
ANGLE IS EXCEEDED

Lubricate all fittings with a good quality lithium based grease such as “Shell Super Duty”, “Mobilith AW2”, “Chevron Ultra Duty II” or equivalent. These greases meet N.L.G.I. #2 specifications and contain 1% Molybdenum Disulfide or less.

* Constant angle applications must have a lube interval of 4 hours.

LUBRICATION GUIDE (Continued)

The operator should become familiar with all lubrication points and establish a systematic routine to insure complete and quick lubrication of the machine.

⚠ WARNING

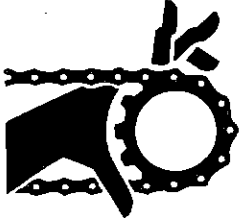

DO NOT CLEAN
OR WORK ON THIS
MACHINE WITHOUT
FIRST DISENGAG-
ING
POWER AND
SHUTTING OFF
TRACTOR ENGINE.

DRIVE CHAINS – Lubricate the drive chains with a light machine oil. Keep chains aligned with sprockets. This will lengthen the life of the sprockets and chain. Lubricate chains often.

GEARBOX – Before using your new spreader, check the oil level in the two beater drive gearboxes. Oil level should be at the center of the shafts in both gearboxes. Use 80W90 gear lube

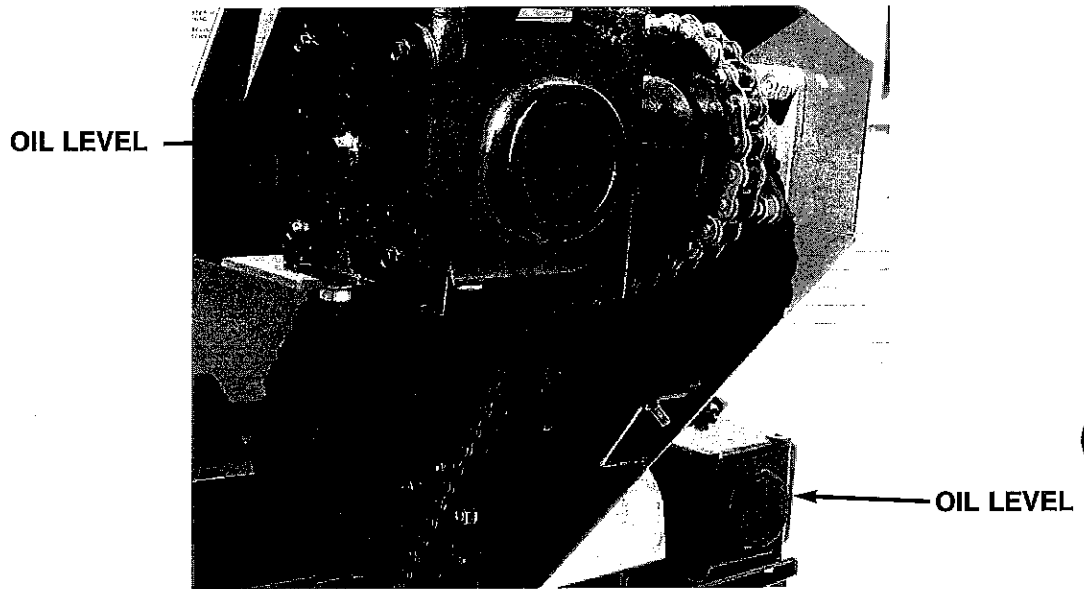

GREASE FITTINGS

There are numerous grease fittings your new spreader. If these are lubricated properly and often enough, it will prolong the life of the spreader. (Grease every 20 hours, also before storage and after power washing.) Unusual or severe conditions may require more frequent lubrication. Make certain that the grease fittings are free of paint and dirt, force a high-quality grease into them until the grease comes out around the shaft on the sleeve-type bearings. On sealed ball bearings, grease should be added slowly until a slight bead forms at the seals indicating the correct amount of lubricant. Wipe off excess grease to prevent the accumulation of chaff and grit around the bearings.

GREASE ZERK LOCATION

Listed below and shown on the following page are the description and location of the grease fittings.

- A. (7) PTO - On each end at U-Joints, one on sliding tube. (See Lubrication Drawing, Page 17).
- B. (2) Front jack shaft (pillow block bearings).
- C. (1) Idler sprocket (right hand auger drive).
- D. (2) One on front of each auger.
- E. (4) Side shaft on left hand side of spreader.
- F. (2) One on each tandem axle pivot tube (remote zerk).
- G. (2) One on each end of internal beater.
- H. (1) Internal beater gearbox input shaft support.
- J. (1) Rear beater right hand support bearing.
- K. (4) One each on road wheel hub (tandem) (2) if single axle.
- L. (1) Main drive gear bearing.
- M. (1) Rear door hinge.
- N. (2) One on each side, tandem walking beam

**SHIELDS REMOVED FOR CLARITY.
DO NOT OPERATE WITH SHIELDS
OPEN OR REMOVED.**

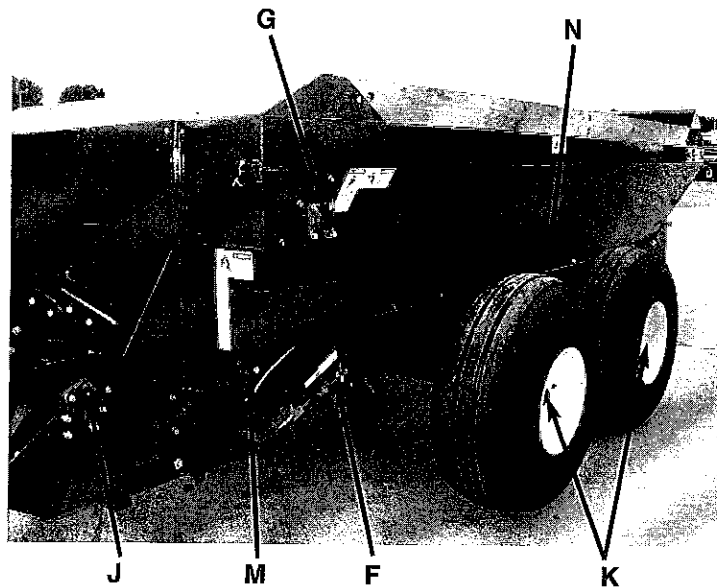
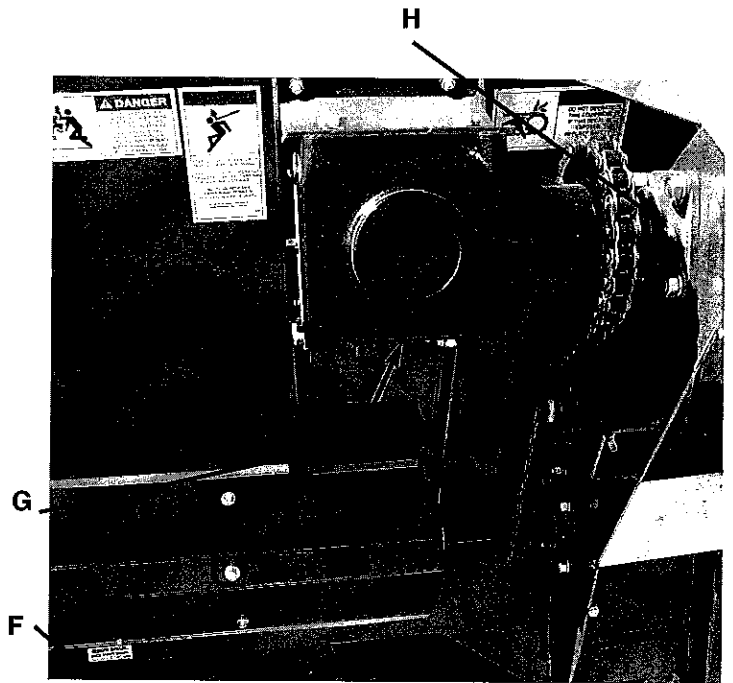
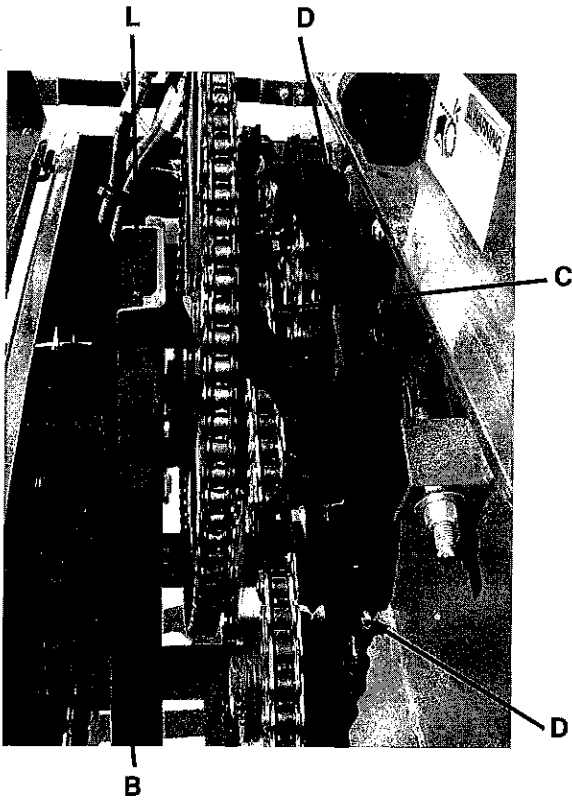
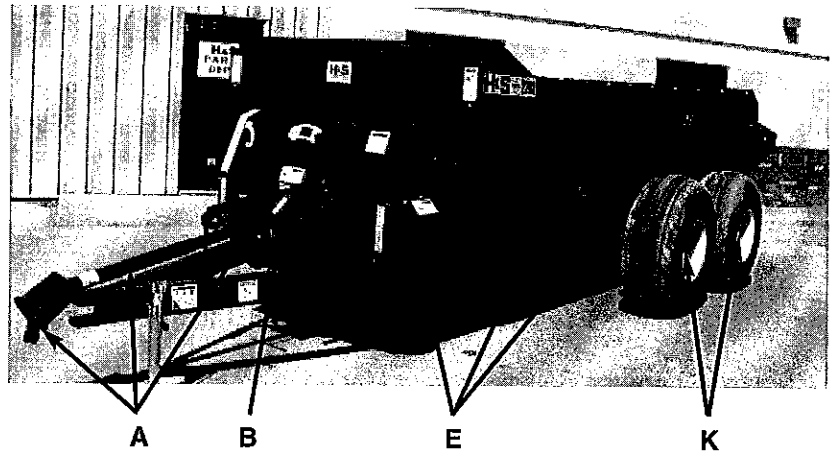

DECAL LOCATION

Your H&S All Purpose Manure Spreader was manufactured with operator safety in mind. Located on the manure spreader are various decals to aid in operation, and warn of danger or caution areas. Pay close attention to all the decals on your Manure Spreader.



DO NOT REMOVE ANY OF THESE DECALS. IF DECALS ARE LOST, DAMAGED, OR IF MANURE SPREADER IS REPAINTED, REPLACE DECALS. REMEMBER: DECALS ARE FOR YOUR PROTECTION AND INFORMATION.

Listed below are the decals on your Manure Spreader. These decals may be ordered individually by part number or by ordering a complete set.

ITEM	PART NO.	DESCRIPTION
A	81605A	(2) Model 1506
	81605B	(2) Model 1806
	81605C	(2) Model 2206
	81605E	(2) Model 2606
	81605D	(2) Model 3306
AA		(2) Red Reflector
B	9194A	(3) Danger - No Step
BB	71494A	(3) Warning - Do Not Operate
C		FEMA Decal
CC	Weasler	Danger - Rotating Driveline (H&S Decal 1494L)
D	72203	Warning - Help Avoid Injuries
DD		Serial -Model Number
E	1494B	Warning - Do Not Remove Shields
EE	102196	PTO Lube
F	9194B	Danger - Never Allow Riders
FF	71188F	Attention: Long Straw
G	1494J	(2) Warning - Do Not Clean or Work
GG	3494A	(2) Remote Grease
H	1494A	(2) Warning - Do Not Operate
HH	82602	Warning - Crushing Hazard
I	11793	Attention: Tractor Half PTO
J	7896C	Rear Door Indicator
K	7896A	Auger Speed Indicator
L	7896D	Direction of Travel Indicator
M	H&S	Patent Number
N	7896B	Shear Bolt Instructions
O	5896B	Danger - Rotating Driveline
P	21897A	Electric Control Box Decal
Q	71188B	Jack Storage Position
R	12794	(3) Warning - Do Not Remove Shields
S	111593B	(2) Danger - Keep Out
T	111593A	(4) Danger - Stay Clear of Beater
U	9894	(2) Danger - Stay Clear of Beater
V	1494K	Warning - Do Not Remove Shields
W	11599	Warning - Do Not Go Near Leaks
X	B8	H&S Decal (5x8)
Y		SMV Decal
Z		(2) Amber Reflector
	1506-9805	Complete Set of Decals - Model 1506
	1806-9805	Complete Set of Decals - Model 1806
	2206-9805	Complete Set of Decals - Model 2206
	2606-9805	Complete Set of Decals - Model 2606
	3306-9805	Complete Set of Decals - Model 3306
Paint - H&S Red		
	ZX21	Gallon
	ZX22	Quart
	ZX23	Pint

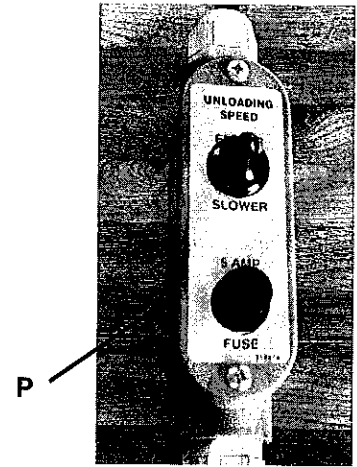
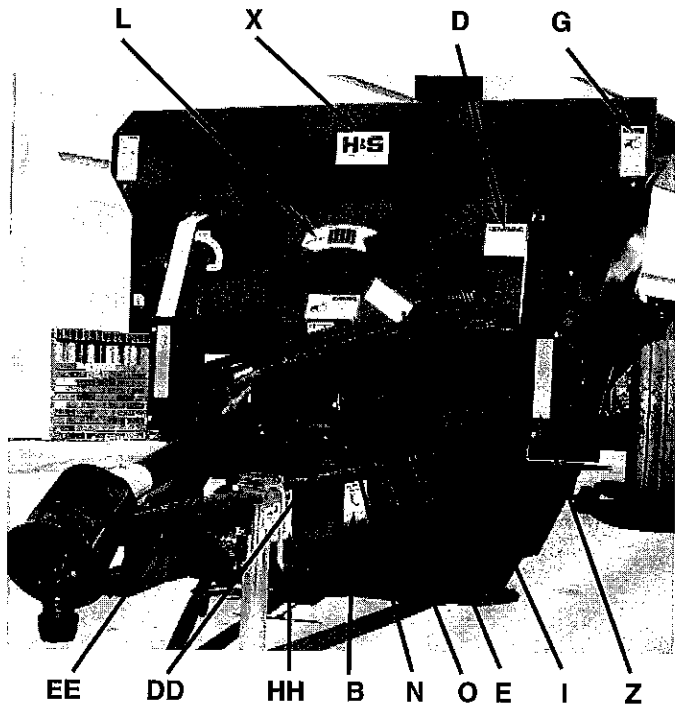

(UNDER SHIELD)

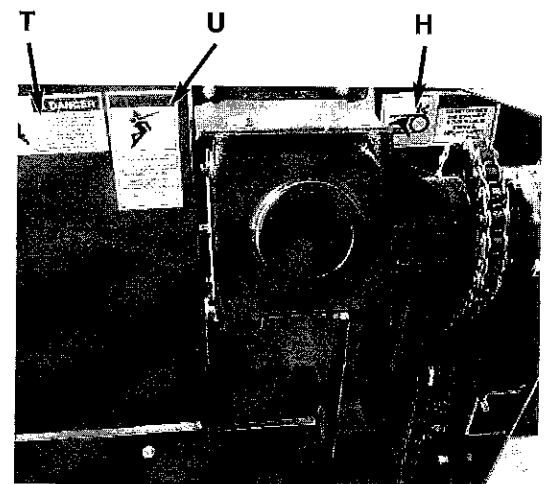
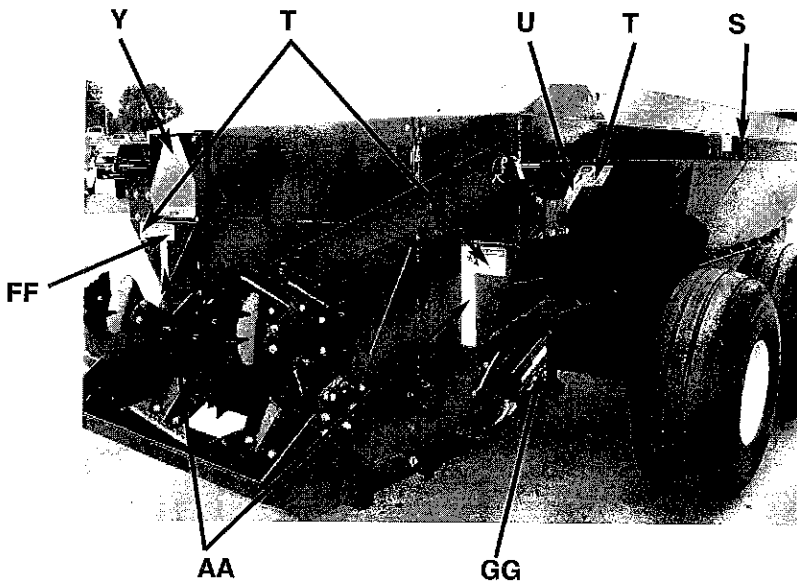
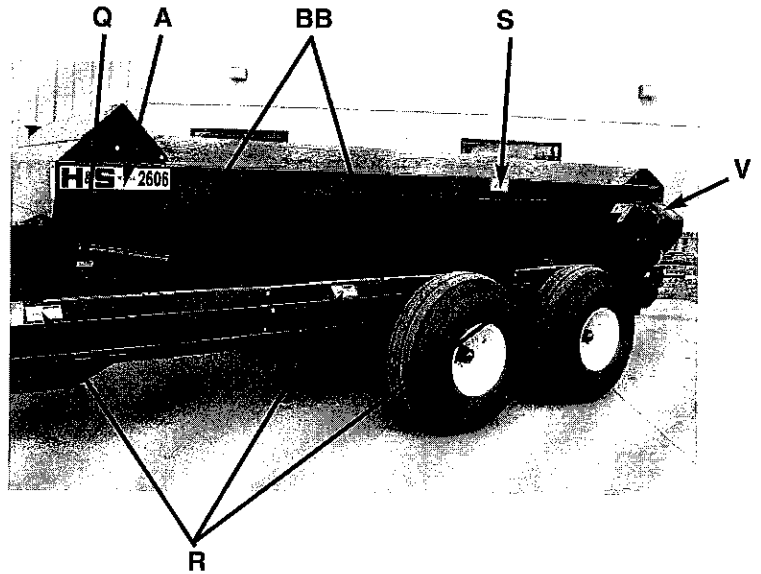
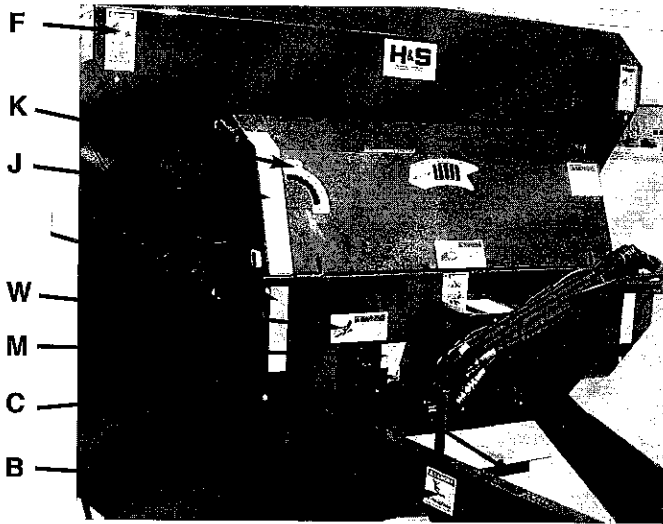

(SHIELDS REMOVED FOR CLARITY)

INSTRUCTIONS FOR ORDERING PARTS

All service parts should be ordered through your authorized H&S dealer. He will be able to give you faster service if you will provide him with the following:

1. Model & Serial Number - Both can be located on the front center frame below the PTO shaft.
2. All reference to left or right apply to the machine as viewed from the rear.
3. Parts should not be ordered from illustration only. Please order by complete part number.
4. If your dealer has to order parts - give shipping instructions:

VIA truck - large pieces (please specify local truck lines)

VIA United Parcel Service (include full address)

H&S MFG. CO. INC.	
MARSHFIELD, WIS.	
MOD. NO.	<input type="text"/>
SER. NO.	<input type="text"/>
DESCR.	<input type="text"/>

PLEASE RECORD NUMBERS FOR YOUR UNIT FOR QUICK REFERENCE

ABOUT IMPROVEMENTS

H&S IS CONTINUALLY STRIVING TO IMPROVE ITS' PRODUCTS.

We must therefore, reserve the right to make improvements or changes whenever it becomes practical to do so, without incurring any obligation to make changes or additions to the equipment previously sold.

FIGURE 1

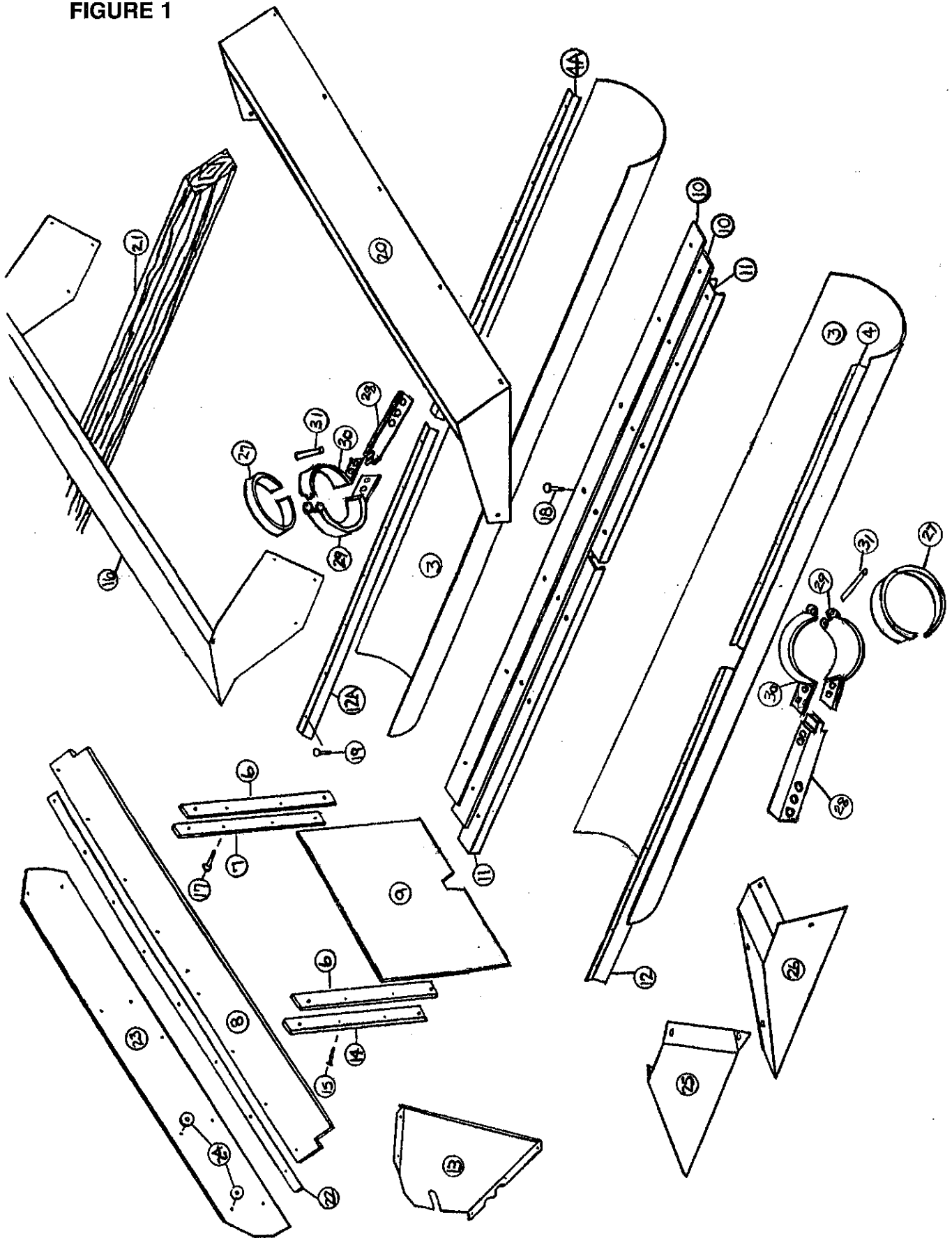

**FIGURE 1
BOX AND COMPONENT PARTS**

ITEM	SPREADER SIZES					DESCRIPTION
	1506	1806	2206	2606	3306	
3.	12SV4	16SV6	"	"	33SV4	Auger Housing Poly
4.	12SV5	16SV7	"	"	33SV5	Auger Wiper RH Front
4A.	12SV5A	16SV7A	"	"	33SV5A	Auger Wiper LH Front
6.	16SV9	"	"	"	"	Door Guide Poly
7.	16SV10	"	"	"	"	LH Door Guide
8.	12SV29	"	16SV11	"	-	Rubber Splash
9.	16SV12	"	"	"	"	Door
10.	12SV6	16SV13	"	"	33SV6	Center Wipers
11.	12SV7	16SV14	"	"	33SV7	Auger Poly Hold Down
12.	12SV8	16SV15	"	"	33SV5A	Auger Wiper RH Back
12A.	12SV8A	16SV15A	"	"	33SV5	Auger Wiper LH Back
13.	12SV44	16SV265	16SV263	"	33SV87	RH Corner Filler
*	12SV45	16SV266	16SV264	"	33SV88	LH Corner Filler
14.	16SV18	"	"	"	"	RH Door Guide
15.	16SV19	"	"	"	"	CTR. Sunk Bolt 1/2" x 2"
16.	-	-	-	-	33SV13	Back Splash Extension
17.	23N194	"	"	"	"	1/2" x 2" Bolt GR.5
18.	16SV21	"	"	"	"	3/8" x 1-1/2" Carr. Bolt GR.5
19.	BFR247	"	"	"	"	3/8" x 1" Carr. Bolt GR.5
20.	16SV216	-	-	16SV216	33SV10	Front Splash
21.	-	-	-	16SV217	-	Wood Rails
*	12SV46	-	-	-	33SV11	Wood Rail LH
*	12SV47	-	-	-	33SV12	Wood Rail RH
22.	12SV30	"	16SV220	"	-	Strap
23.	12SV31	"	-	-	-	Back Splash Poly
24.	12SV32	"	-	-	-	Back Splash Poly Washer
25.	-	12SV40	-	-	-	Back Splash Gusset RH
*	-	12SV42	-	-	-	Back Splash Gusset LH
26.	12SV41	-	-	-	-	Back Splash Gusset RH
*	12SV43	-	-	-	-	Back Splash Gusset LH
27.	16SV404	"	"	"	"	Poly Bearing
28.	16SV405	"	"	"	"	Auger Bearing Post
29.	16SV406	"	"	"	"	Auger Bearing Cap A
30.	16SV407	"	"	"	"	Auger Bearing Cap B
31.	16SV408	"	"	"	"	Pin
*	16SV409	"	"	"	"	Shim (as needed)

NOT SHOWN:

OPTIONAL HIGH SPLASHES

-	16SV359	16SV361	16SV360	-	High-Back Splash Extension
-	16SV369	16SV362	16SV363	-	Hi-Front Splash Extension

NOTE: * (Means Not Shown)

" (Means Same as Preceding Number)

- (Means Not Used on This Model)

FIGURE 2

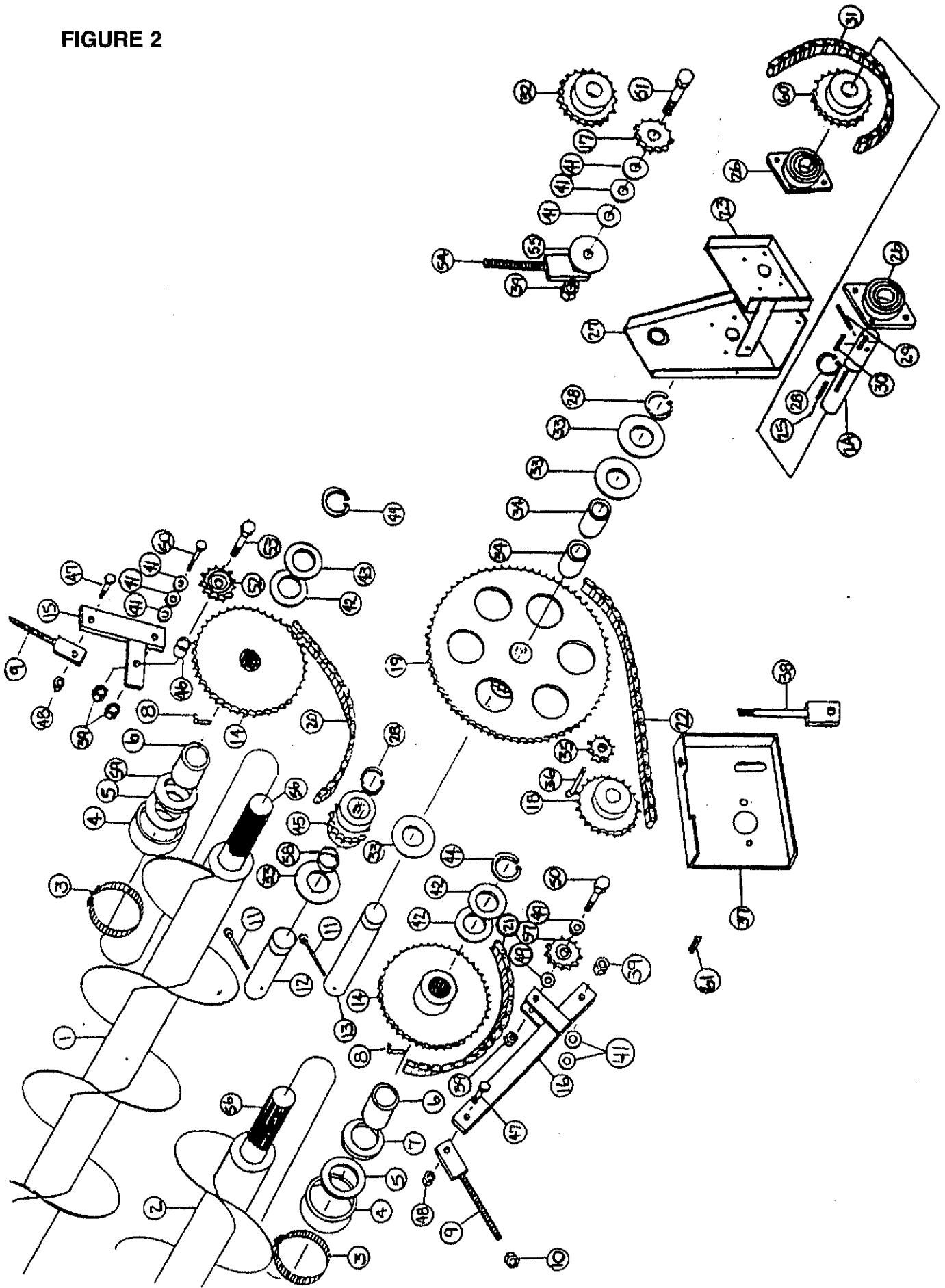
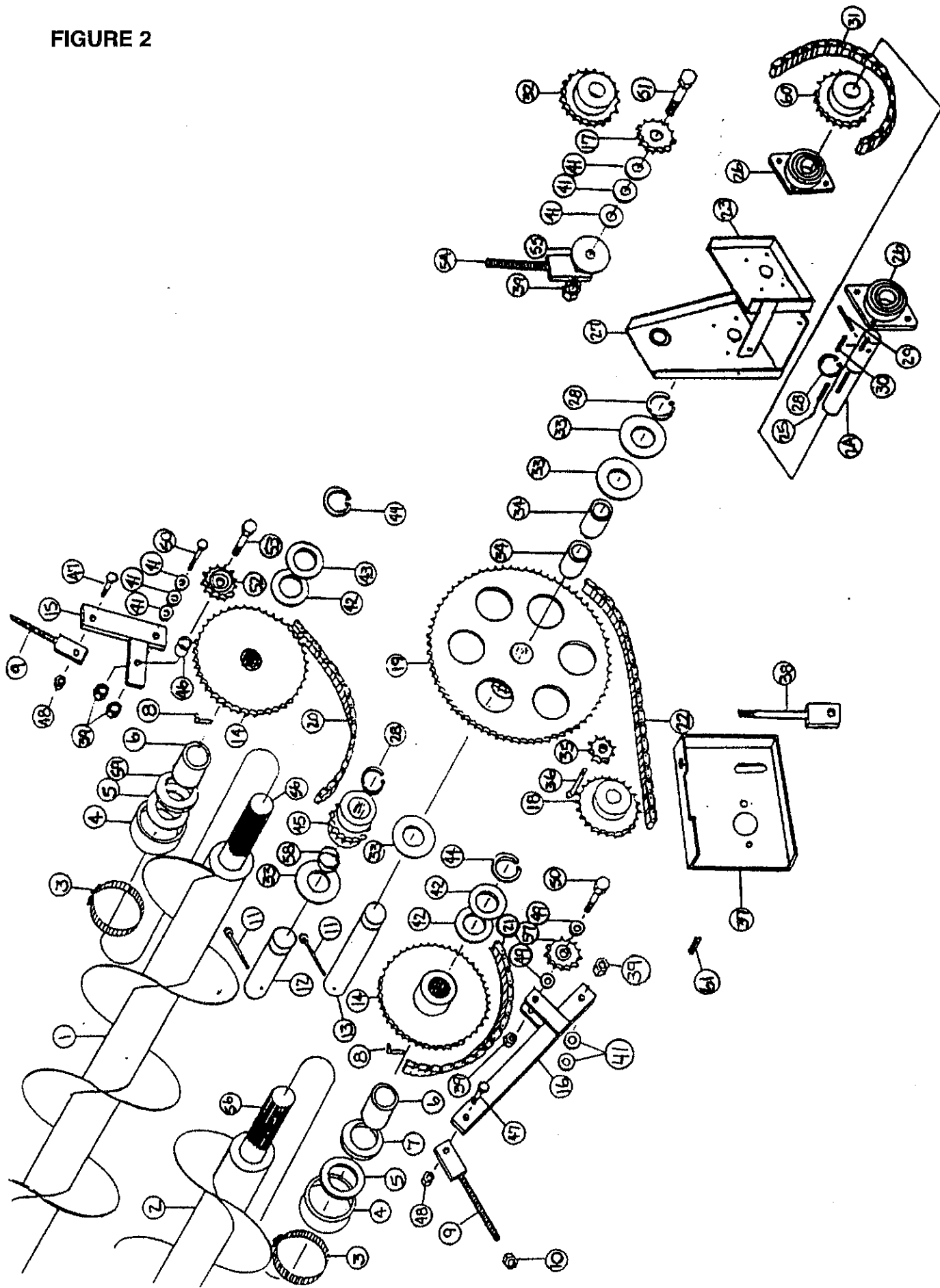

**FIGURE 2
AUGERS AND DRIVE ASSEMBLY**

ITEM	SPREADER SIZES					DESCRIPTION
	1506	1806	2206	2606	3306	
1.	12SV53	16SV401	"	"	33SV108	LH Auger
2.	12SV54	16SV402	"	"	33SV109	RH Auger
3.	12V70	"	"	"	"	Clamp
4.	16SV24	"	"	"	"	Outer Seal
5.	16SV25	"	"	"	-	Inner Seal
*	-	-	-	-	33SV16	RH Spacer
*	-	-	-	-	12V74	LH Spacer
6.	12V73	"	"	"	"	Bronze Bushing
7.	12V72	"	"	"	33SV17	Bronze Thrust Washer
8.	16SV26	"	"	"	"	Pipe Grease Zerk
9.	12V78	"	"	"	"	Tightener Bracket
10.	R29	"	"	"	"	1/2" Nut
11.	23N1	"	"	"	"	Bolt 5/16" x 5" GR.5
12.	16SV27	"	"	"	33SV18	Idler Shaft
13.	16SV28	"	"	"	33SV19	Primary Shaft
14.	12V81	"	"	"	-	45T Sprocket
*	-	-	-	-	33SV20	35T Sprocket
15.	16SV30	"	"	"	33SV22	LH Tightener
16.	16SV29	"	"	"	33SV21	RH Tightener
17.	12V77	"	"	"	"	12T Idler Sprocket
18.	12SV11	"	16SV31	"	"	16T Sprocket
19.	16SV32	"	"	"	33SV23	98T Main Drive Sprocket
20.	16SV33	"	"	"	-	LH Final Drive Chain #80 x 59 Pitch
*	-	-	-	-	33SV24	LH Final Drive Chain #100 x 46 Pitch
21.	16SV34	"	"	"	-	RH Final Drive Chain #80 x 79 Pitch
*	-	-	-	-	33SV25	RH Final Drive Chain #100 x 62 Pitch
22.	16SV35	"	"	"	"	Auger Primary Drive Chain #60 x 110 Pitch
23.	16SV301	"	"	"	"	Front Post
24.	16SV302	"	"	"	"	Input Shaft
25.	PB87	"	"	"	"	3/8" x 2" Sq. Key
26.	12V67	"	"	"	"	Bearing Assembly
27.	16SV303	"	"	"	"	Rear Input Post
28.	12V62	"	"	"	"	Snap Ring
29.	16SV379	"	"	"	"	3/8" x 2-1/2" Roll Pin
30.	S38	"	"	"	"	3/8" x 2-3/8" Sq. Key
31.	16SV39	"	"	"	"	Side Shaft Chain #80 x 75 Pitch
*	-	-	-	-	33SV64	Side Shaft Chain #80 x 73 Pitch
32.	12V104	"	"	"	-	20T Sprocket
*	Optional	Optional	Optional	Optional	16SV213	23T Sprocket (1000 RPM)

(Continued on Pages 28 & 29)

FIGURE 2



**FIGURE 2
AUGERS AND DRIVE ASSEMBLY**

ITEM	SPREADER SIZE					DESCRIPTION
	1506	1806	2206	2606	3306	
33.	16SV40	"	"	"	"	Shim
34.	16SV41	"	"	"	"	Bronze Bushing 1-3/4"ODx1-1/2"IDx2-3/8"
35.	12N42	"	"	"	"	15T Sprocket
36.	16SV91	"	"	"	"	Bolt 1/2" x 3-1/4" GR.5
37.	16SV42	"	"	"	"	Motor Mount
38.	16SV43	"	"	"	"	Tightener Bracket
39.	HE7	"	"	"	"	3/4" Nut
41.	T73	"	"	"	"	Shim
42.	16SV45	"	"	"	"	Shim 3/16"
43.	16SV46	"	"	"	"	Shim 1/4"
44.	B17F	"	"	"	"	Snap Ring
45.	16SV47	"	"	"	"	12T Idler Sprocket
*	-	-	-	-	33SV27	9T Idler Sprocket
46.	16SV48	"	"	"	"	Spacer
47.	12V45	"	"	"	"	1/2" x 1-1/2" Bolt GR.5
48.	9S17	"	"	"	"	1/2" Lock Nut
49.	16SV49	"	"	"	"	Shim 1/16"
50.	HE8	"	"	"	"	3/4" x 2-1/4" Bolt GR.5
51.	16SV50	"	"	"	"	3/4" x 2-1/2" Bolt GR.5
52.	16SV328	"	"	"	-	Reinforced 12T Idler Sprocket
*	-	-	-	-	33SV1	Reinforced 9T Idler Sprocket
53.	16SV202	"	"	"	"	3/4" x 3-3/4" Bolt GR.5
54.	16SV204	"	"	"	"	Tightener Mount
55.	16SV211	"	"	"	"	Spacer
56.	16SV222	"	"	"	33SV86	Splined Shaft w/Auger End
57.	12V77	"	"	"	-	12T Idler Sprocket
*	-	-	-	-	33SV30	9T Idler Sprocket
58.	-	-	-	-	33SV29	Reverse Idler Spacer
59.	12V72	"	"	"	33SV17	Bronze Thrust Washer
*	-	-	-	-	33SV16	LH Auger Spacer
60.	12V104	"	"	"	-	20T Sprocket
*	Optional	Optional	Optional	Optional	ST11	13T Sprocket (1000 RPM)
61.	5B10	"	-	-	-	Key 1/4" x 1" Woodruff Key
*	-	-	G23	"	"	Key 5/16" x 1-3/8" Sq. Key

NOTE: * (Means Not Shown)

" (Means Same as Preceding Number)

- (Means Not Used on This Model)

FIGURE 3

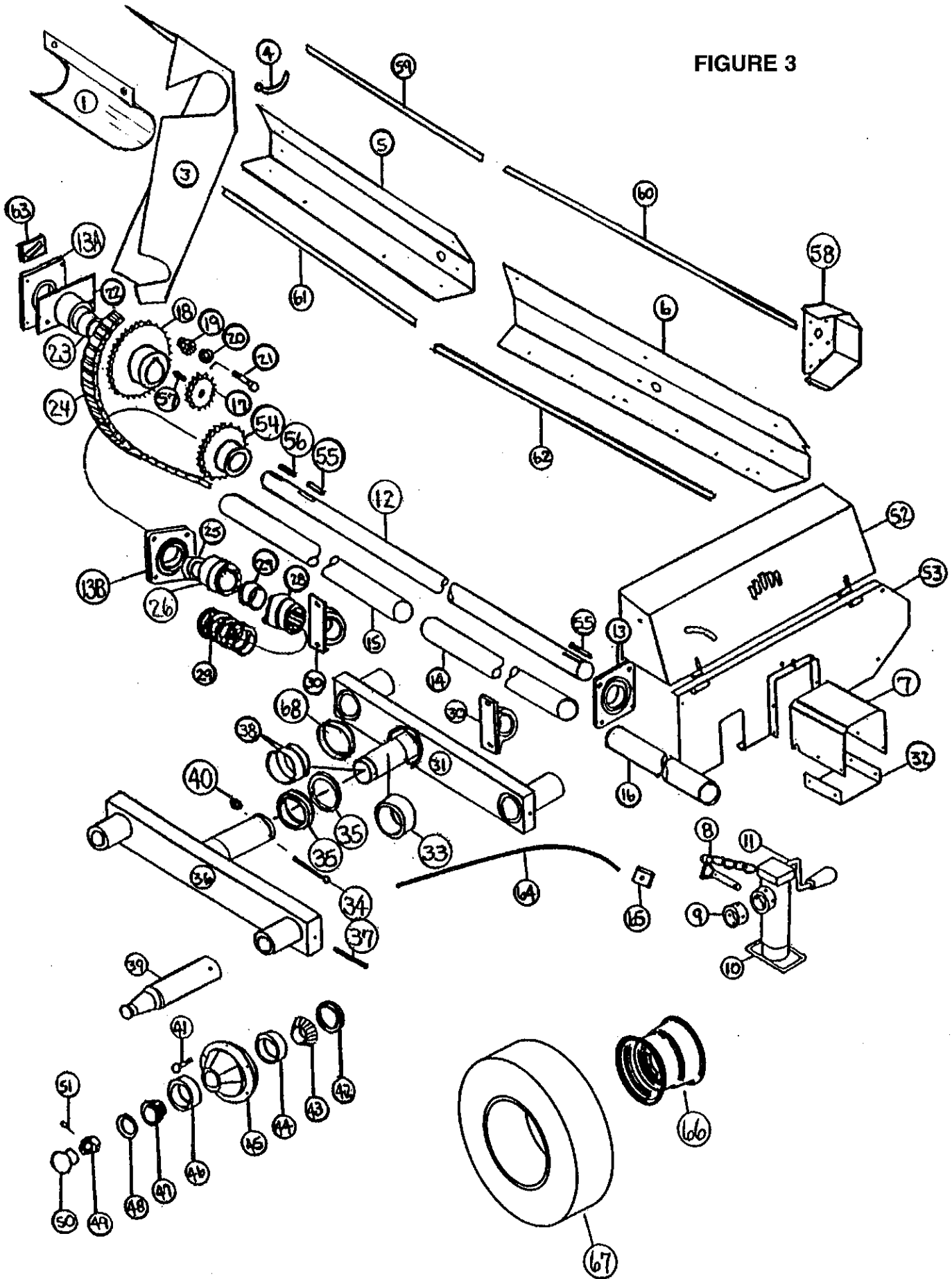
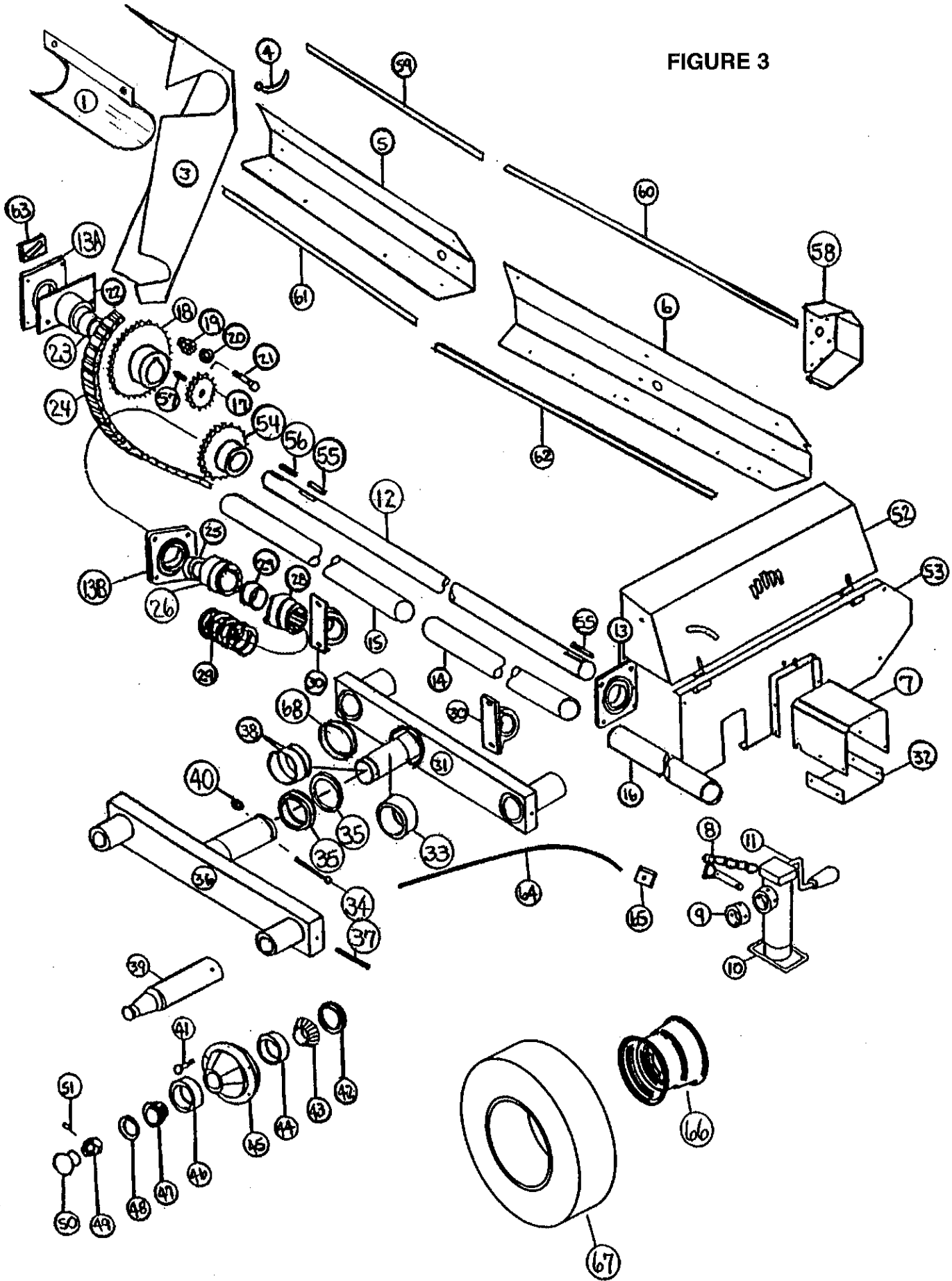

**FIGURE 3
SHIELDS, SIDE SHAFT AND AXLE ASSEMBLIES**

ITEM	SPREADER SIZES					DESCRIPTION
	1506	1806	2206	2606	3306	
1.	16SV415	"	"	"	"	Clutch Shield
3.	16SV53	"	16SV257	"	"	Top Beater Shield
4.	S192	"	"	"	"	Handle Nut
5.	12SV12	16SV54	16SV55	"	33SV31	Rear Side Shield
6.	12SV13	16SV56	16SV57	"	33SV32	Front Side Shield
7.	16SV329	"	"	"	"	PTO Shield
8.	12N13	"	"	"	"	Jack Pin
9.	12N14	"	"	"	"	Jack Mount
10.	27N14	"	"	"	"	Jack
11.	12N12	"	"	"	"	Jack Handle
*	12N9	"	"	"	"	Jack Gear Replacement Kit
12.	12SV14	16SV59	"	"	33SV33	Side Shaft
13.	12V67	"	"	"	"	Pillow Block Bearing
13A.	-	-	12V67	"	"	Pillow Block Bearing
13B.	33SV106	"	"	"	"	Pillow Block Bearing H.D.
14.	-	16SV60	"	"	33SV34	Side Center PVC Shield
15.	12SV15	16SV61	"	"	"	Side Back PVC Shield
16.	12SV16	16SV62	"	"	33SV35	Side Front PVC Shield
17.	12V77	"	"	"	"	12T Idler Sprocket
18.	16SV63	"	"	"	"	23T Beater Sprocket
19.	16SV64	"	"	"	"	3/4" Flange Nut
20.	T73	"	"	"	"	Shim
21.	HE8	"	"	"	"	Bolt 3/4" x 2-1/4" GR.5
22.	16SV65	"	-	-	-	Outer Bearing
23.	16SV66	"	-	-	-	Bronze Bushing 1-3/4"ODx1-1/2"IDx2-1/8"
24.	16SV67	"	-	-	-	2nd Beater Chain #80 64 Pitch
*	-	-	16SV330	"	"	2nd Beater Chain #80 68 Pitch
25.	33SV107	"	"	"	"	Clutch Stop
26.	16SV69	"	"	"	"	Keyed Clutch
27.	16SV70	"	"	"	"	Bronze Bushing 1-1/2"ODx1"IDx3/4"
28.	16SV71	"	"	"	"	Splined Clutch
29.	23N89	"	"	"	"	Spring
30.	16SV72	"	"	"	"	Pillow Block Bearing
31.	-	16SV73	16SV74	"	33SV36	Tandem Beam LH
Optional	12SV17	-	-	-	-	Tandem Beam LH
32.	16SV327	"	"	"	"	PTO Shield Bottom
33.	B58	"	16SV75	"	"	Bushing for Tandem Axle
34.	B61	"	-	-	-	1/2" x 5" Bolt GR.5 (For Axle)
*	-	-	16SV77	"	"	1/2" x 6" Bolt GR.5 (For Axle)
35.	16SV78	"	16SV214	"	"	Collar for Axle
36.	-	16SV80	16SV81	"	33SV37	Tandem Beam RH
Optional	12SV18	-	-	-	-	Tandem Beam RH
37.	31N4	"	"	"	"	Roll Pin
38.	16SV82	"	16SV83	"	"	Inner Bushing

(Continued on Pages 32 & 33)

FIGURE 3

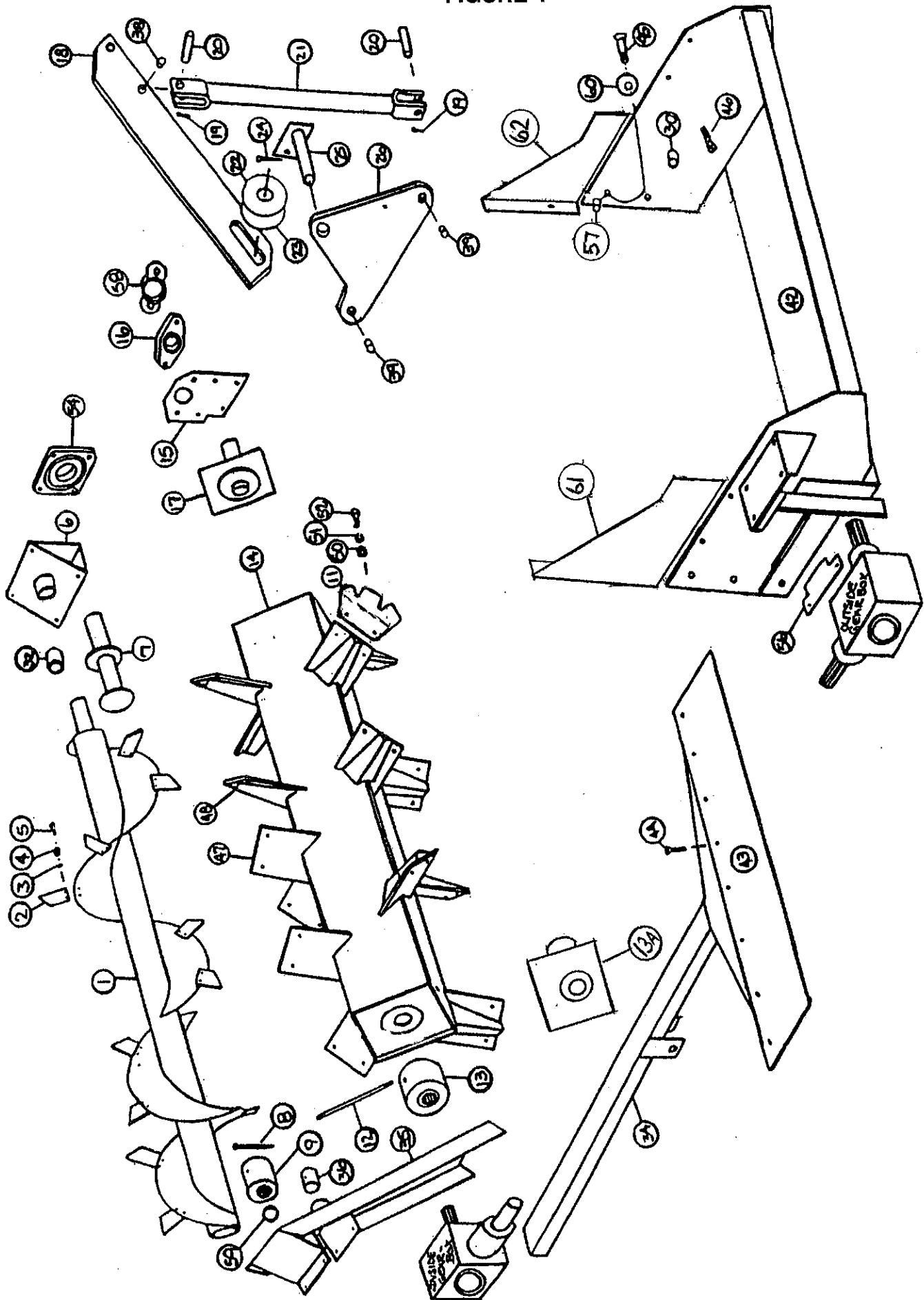

**FIGURE 3
SHIELDS, SIDE SHAFT AND AXLE ASSEMBLIES**

ITEM	SPREADER SIZES					DESCRIPTION
	1506	1806	2206	2606	3306	
39.	12SV26	37N8	16SV85	"	33SV40	Standard Spindle
Optional	-	16SV203	-	-	-	Spindle for 14 x 16.1 Wheel
Optional	31N2	-	-	-	-	Spindle for 8 x 22.5 Wheel
Optional	12SV26	16SV203	16SV85	"	-	Spindle for 13.5 x 22.5 Wheel
40.	9S17	"	"	"	"	1/2" Top Lock Nut
41.	26G5	"	"	"	33SV41	Stud
*	26G6	"	"	"	RG72	Nut for Stud
Optional	B32	-	-	-	-	Hub Bolt - Used w/Tandem Option
42.	B90	"	"	"	33SV42	Seal
Optional	B8	-	-	-	-	Seal - Used w/Tandem Option
43.	B91	"	"	"	33SV43	Inner Bearing
Optional	B7	-	-	-	-	Inner Bearing - Used w/Tandem Option
44.	B91A	"	"	"	33SV44	Inner Race
Optional	B7A	-	-	-	-	Inner Race - Used w/Tandem Option
45.	26G4A	"	"	"	33SV45	Hub
Optional	B6	-	-	-	-	Hub - Used w/Tandem Option
46.	B94A	"	"	"	RG169	Outer Race
Optional	B5A	-	-	-	-	Outer Race - Used w/Tandem Option
47.	B94	"	"	"	RG170	Outer Bearing
Optional	B5	-	-	-	-	Outer Bearing - Used w/Tandem Option
48.	B4	"	"	"	33SV95	Washer
49.	B3	"	"	"	RG17	1" Slotted Nut
50.	B2	"	"	"	RG171	Hub Cap
51.	B31	"	"	"	33SV46	Cotter Pin
52.	16SV322	"	"	"	16SV323	Main Shield
53.	16SV324	"	"	"	16SV325	Main Shield Bottom
54.	ST11	"	"	"	"	13T Sprocket
55.	PB87	"	"	"	"	Key 3/8" x 2" Sq.
56.	A32	"	"	"	"	Key 3/8" x 1-3/8" Sq.
57.	16SV350	"	"	"	"	Key 3/8" x 2" Round Ends
58.	16SV326	"	"	"	"	Bearing Mount
59.	12SV35	16SV226	"	"	33SV38	Plastic Edging
60.	12SV33	16SV224	"	"	33SV48	Plastic Edging
61.	12SV36	16SV227	"	"	33SV50	Plastic Edging
62.	12SV34	16SV225	"	"	33SV49	Plastic Edging
63.	16SV355	"	"	"	"	Pillow Block Wedge
64.	-	-	16SV364	"	33SV103	Grease Line
65.	-	-	16V9	"	"	Grease Block
66.	12V36	-	"	"	-	Wheel 14 x 16.1
*	-	23N179	-	-	-	Wheel 8.250 x 22.5
Optional	16SV89	"	"	"	16SV89	Wheel 13.5 x 22.5
Optional	23N179	-	-	-	-	Wheel 13.5 x 22.5
Optional	-	12V36	-	-	-	Wheel 8.250 x 22.5
Optional	-	-	33SV105	"	"	Wheel 14 x 16.1
Optional	-	-	-	-	-	Wheel 16 x 16.1
67.	23N54	-	"	"	-	Tire 16.5 x 16.1
*	-	-	-	-	16SV88	Tire (TRUCK)
*	-	23N180	-	-	-	Tire 11 x 22.5
Optional	16SV88	"	"	"	-	Tire (TRUCK)
Optional	-	23N54	-	-	-	Tire 16.5 x 16.1
Optional	-	-	12V37	"	"	Tire 19L x 16.1
Optional	23N180	-	-	-	-	Tire 11 x 22.5
68.	-	B111	-	-	-	Phenolic Bushing

NOTE: * (Means Not Shown)
 " (Means Same as Preceding Number)
 - (Means Not Used on This Model)

FIGURE 4

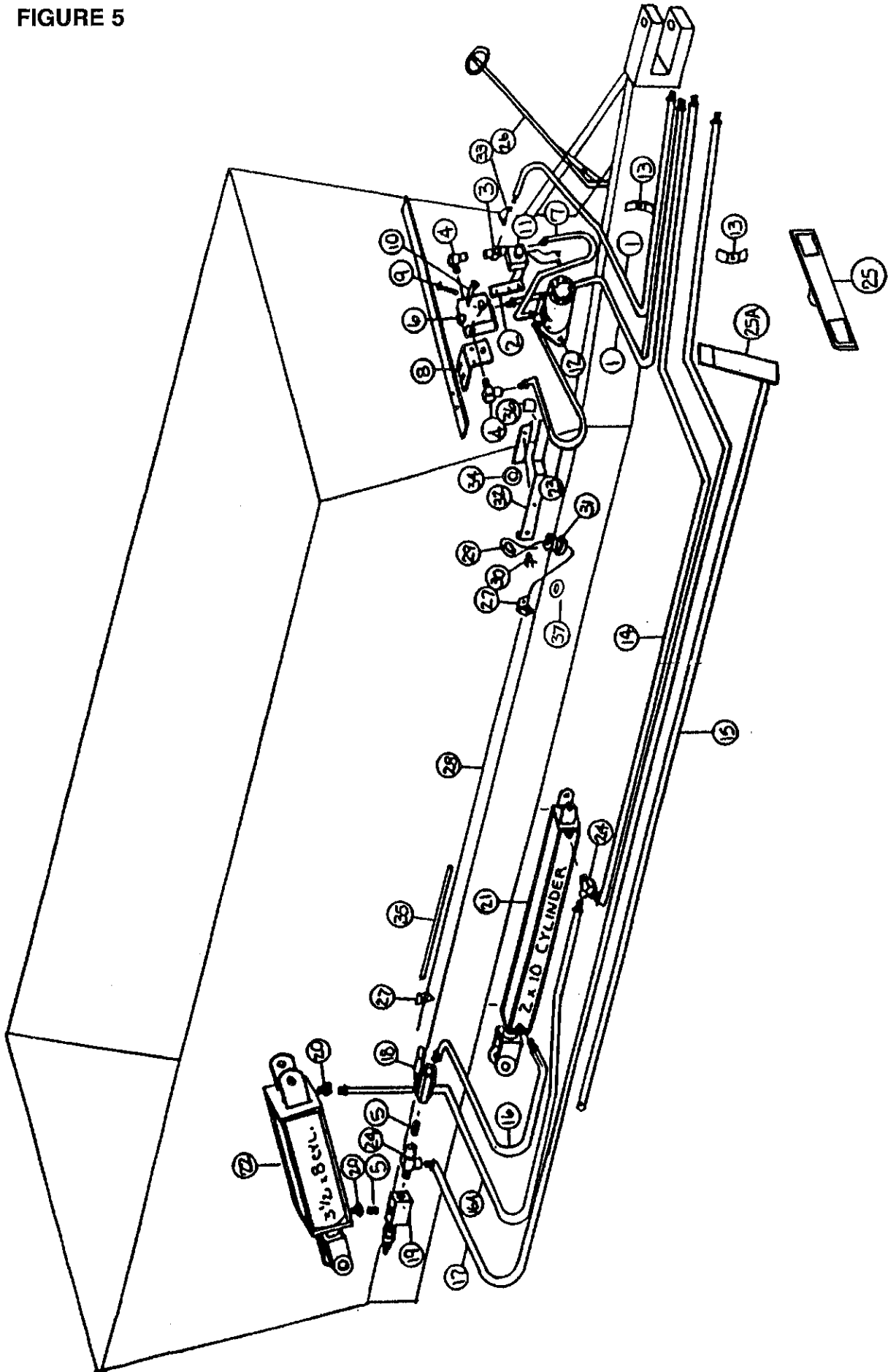

**FIGURE 4
BEATERS AND PAN ASSEMBLIES**

ITEM	SPREADER SIZES					DESCRIPTION
	1506	1806	2206	2606	3306	
1.	33SV51	"	33SV104	"	"	Inside Beater
2.	16SV93	"	"	"	"	Beater Tooth
3.	R35	"	"	"	"	1/2" Lock Washer
4.	R11	"	"	"	"	1/2" Lock Nut
5.	R10	"	"	"	"	Bolt 1/2" x 1-1/4"
6.	33SV52	"	"	"	"	RH Beater Bearing
7.	33SV53	"	"	"	"	Beater Stub Shaft
8.	23N1	"	"	"	"	Bolt 5/16" x 5" GR.5
9.	23N2	"	43NW1	"	"	Splined Beater Insert
11.	16SV416	"	"	"	"	Beater Blade
12.	16SV308	"	"	"	"	Beater Bolt
13.	23N2	"	"	"	"	Splined Beater Insert
13A.	16SV381	"	"	"	"	Beater Insert W/ Plate
14.	16SV400	"	"	"	"	Beater
15.	16SV309	"	"	"	"	Beater Bearing Mount
16.	16SV336	"	"	"	"	Pillow Block Bearing
17.	16SV310	"	"	"	"	Beater Stub Shaft
18.	16SV103	"	"	"	33SV54	Door Lift Bar
19.	T72	"	"	"	"	5/32" x 1-1/2" Cotter Pin
20.	16SV104	"	"	"	"	Lifting Arm Pins
21.	16SV105	"	"	"	"	Lifting Arm
22.	16SV106	"	"	"	"	Washer
23.	16SV107	"	"	"	"	Poly Door Washer
24.	16SV108	"	"	"	"	Cotter Pin
25.	16SV340	"	"	"	"	Bell Crank Hinge
26.	16SV273	"	"	"	"	Bell Crank
30.	16SV210	"	"	"	"	Spacer 15/16" x 1"
32.	16SV215	"	"	"	"	Bushing
34.	12SV48	16SV311	"	"	33SV89	Clean-Out Door
35.	16SV119	"	16SV268	"	"	Gearbox Mount
36.	16SV120	"	S44	"	"	Bronze Bushing
38.	16SV261	"	"	"	"	Door Lift Bar Bushing
39.	16SV262	"	"	"	"	Bell Crank Bushing
42.	16SV403	"	"	"	"	Back Pan
43.	16SV312	"	"	"	"	Clean-Out Door Poly
44.	16SV124	"	"	"	"	Bolt 5/16" x 1" Counter Sunk
45.	16SV125	"	"	"	"	Bolt 1/2" x 1-3/4" Counter Sunk
46.	16SV126	"	"	"	"	Bolt 1/2" x 2" Counter Sunk
47.	16SV313A	"	"	"	"	LH Blade Holder
48.	16SV314A	"	"	"	"	RH Blade Holder
50.	R10	"	"	"	"	1/2-13 x 1-1/4" Bolt GR.5
51.	R35	"	"	"	"	1/2" Lock Washer
52.	R11	"	"	"	"	1/2" Lock Nut
54.	33SV65	"	"	"	"	Inside Beater Bearing
56.	16SV315	"	"	"	"	Beater Wiper
57.	X112	"	"	"	"	Spacer 9/16" x 1"
58.	16SV346	"	"	"	"	Bearing Cap
59.	-	-	16SV353	"	"	Seal
60.	16SV116	"	"	"	"	Door Stop Washer
61.	16SV417	"	"	"	"	Pan Extention LH
62.	16SV418	"	"	"	"	Pan Extention RH

NOTE: " (Means Same as Preceding Number)

FIGURE 5



**FIGURE 5
HYDRAULICS**

ITEM	SPREADER SIZES					DESCRIPTION
	1506	1806	2206	2606	3306	
1.	16SV129	"	"	"	"	Hose 1/2" x 108"
2.	16SV245	"	"	"	"	Speed Control Motor Mount
3.	16SV352	"	"	"	"	Service Tee 1/2"
4.	HE58	"	"	"	"	1/2" Hyd. Street Elbow
5.	16SV351	"	"	"	"	3/8" Male Coupling
6.	16SV347	"	"	"	"	Speed Control Valve
7.	16SV143	"	-	-	-	Hose 1/2" x 19"
*	-	-	16SV144	"	"	Hose 1/2" x 41"
8.	16SV331	"	"	"	33SV94	Valve Mount
9.	X26	"	"	"	"	Bolt 3/8" x 3" Full Thread
10.	16SV242	"	"	"	"	Speed Valve Pointer
11.	16SV246	"	"	"	"	Gear Motor
12.	16SV149	"	16SV150	"	"	Motor
13.	23N67	"	"	"	"	Hydraulic Hose Holder
14.	12SV51	-	-	-	-	Hose 3/8" x 236"
*	-	23N302	"	"	-	Hose 3/8" x 264"
*	-	-	-	-	27N45	Hose 3/8" x 288"
15.	12SV50	16SV337	"	"	33SV93	Door Rod
16.	-	BFR53	"	"	"	Hose 3/8" x 56"
*	12SV23	-	-	-	-	Hose 3/8" x 36"
16A.	BFR53	"	"	"	-	Hose 3/8" x 56"
*	-	-	-	-	33SV60	Hose 3/8" x 68"
17.	12SV52	-	-	-	-	Hose 3/8" x 256"
*	-	27N45	"	"	-	Hose 3/8" x 288"
*	-	-	-	-	37N80	Hose 3/8" x 318"
18.	16SV338	"	"	"	"	Ball Valve
19.	16SV339	"	"	"	"	Sequence Valve
20.	JB82	"	"	"	"	1/2" to 3/8" Bushing
21.	16SV171	"	"	"	"	2" x 10" Cylinder
22.	16SV167	"	"	"	"	3-1/2" x 8" Cylinder
23.	16SV141	"	"	"	"	Hose 1/2" x 24"
*	-	-	16SV142	"	"	Hose 1/2" x 46"
24.	23N116	"	"	"	"	3/8" Tee
25.	16SV148A	"	"	"	"	Indicator Bar (Standard)
25A.	16SV148	"	"	"	"	Indicator Bar (Removable Hitch)
26.	16SV332	"	"	"	"	Hose Holder
27.	16SV333	"	"	"	"	Cable Guide
28.	12SV49	16SV334	"	"	33SV90	Cable
29.	ES14	"	"	"	"	Thimble
30.	16SV342	"	"	"	"	Cable Clamp
31.	F33	"	"	"	"	Cable Insulator
32.	16SV335	"	"	"	"	Pointer
33.	HE58	"	"	"	"	Street Elbow 1/2"
34.	16SV354	"	"	"	"	Pointer Washer
35.	16SV365	"	"	"	"	Cable Guard
36.	16SV366	"	"	"	"	Pointer Shielding
37.	ST57	"	"	"	"	Plastic Cable Grommet

NOTE: * (Means Not Shown)

" (Means Same as Preceding Number)

- (Means Not Used on This Model)

FIGURE 6
21-GEAR BOX COMPLETE

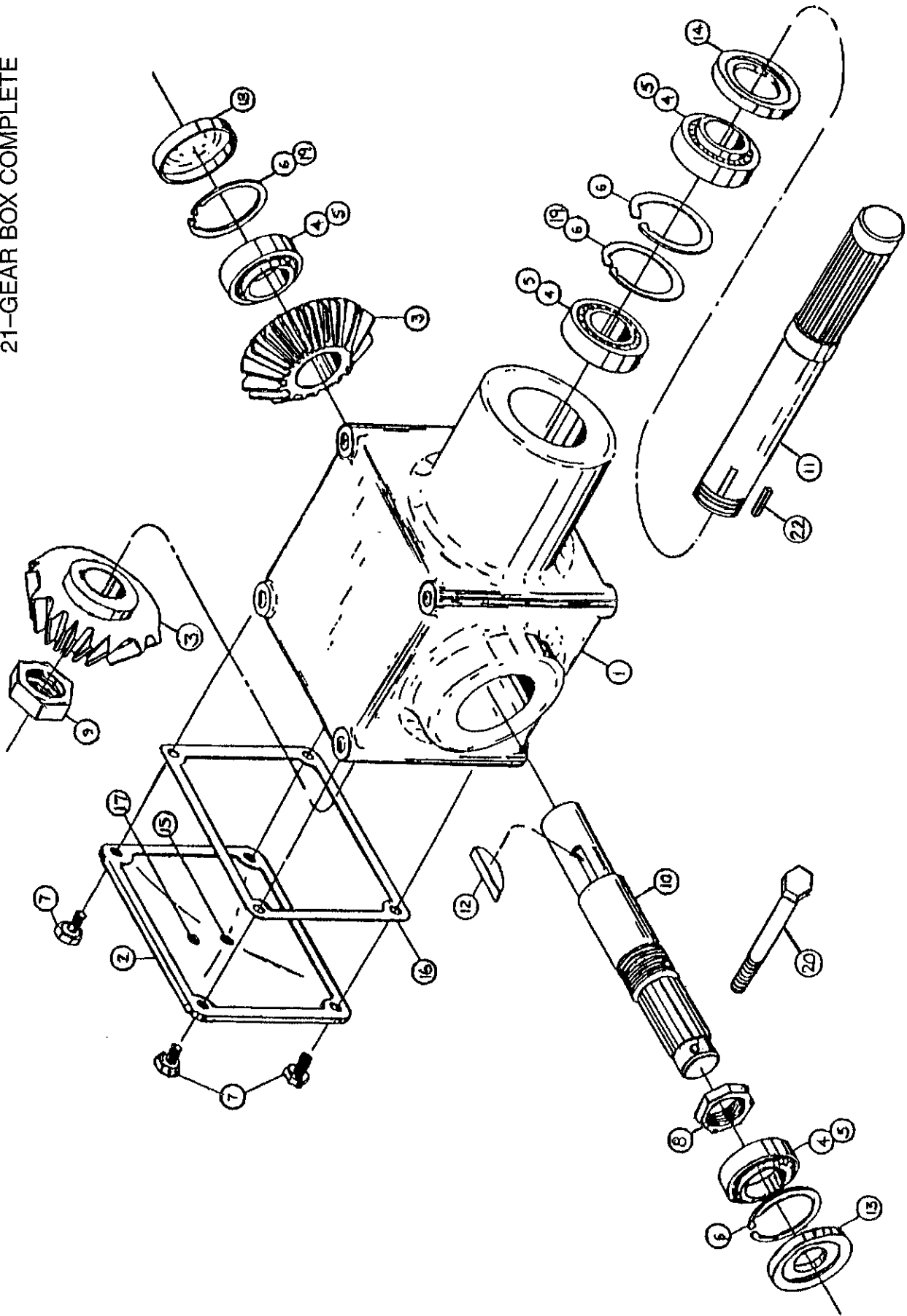

FIGURE 6
GEARBOX - OUTSIDE BEATER

ITEM	SPREADER SIZES					DESCRIPTION
	1506	1806	2206	2606	3306	
1.	G50	"	"	"	"	Housing
2.	G51	"	"	"	"	Cover
3.	G52	"	"	"	"	Bevel Gear
4.	G53	"	"	"	"	Bearing #14137A
5.	G54	"	"	"	"	Bearing Cup #14276
6.	G55	"	"	"	"	Snap Ring
7.	G56	"	"	"	"	Capscrew
8.	G57	"	"	"	"	1-1/2" Stake Nut
9.	G58	"	"	"	"	1-3/8" Stake Nut
10.	23N137	"	"	"	"	Output Shaft
11.	G94	"	"	"	"	Input Shaft
12.	G61	"	"	"	"	"E" (1210) Woodruff Key
13.	G63	"	"	"	"	Seal - Output
14.	G64	"	"	"	"	Seal - Input
15.	G65	"	"	"	"	Plug 3/8" NPT
16.	G66	"	"	"	"	Gasket
17.	G67	"	"	"	"	Plug 1/8" NPT
18.	G68	"	"	"	"	Cap
19.	G69	"	"	"	"	Shim
20.	23N1	"	"	"	"	5/16" x 5" Bolt GR.5
21.	16SV156	"	"	"	"	Bevel Gearbox Complete
22.	G62	"	"	"	"	Key 3/8" Sq. x 1-3/8" Hardened

NOTE: " (Means Same as Preceding Number)

FIGURE 7
21-GEAR BOX COMPLETE

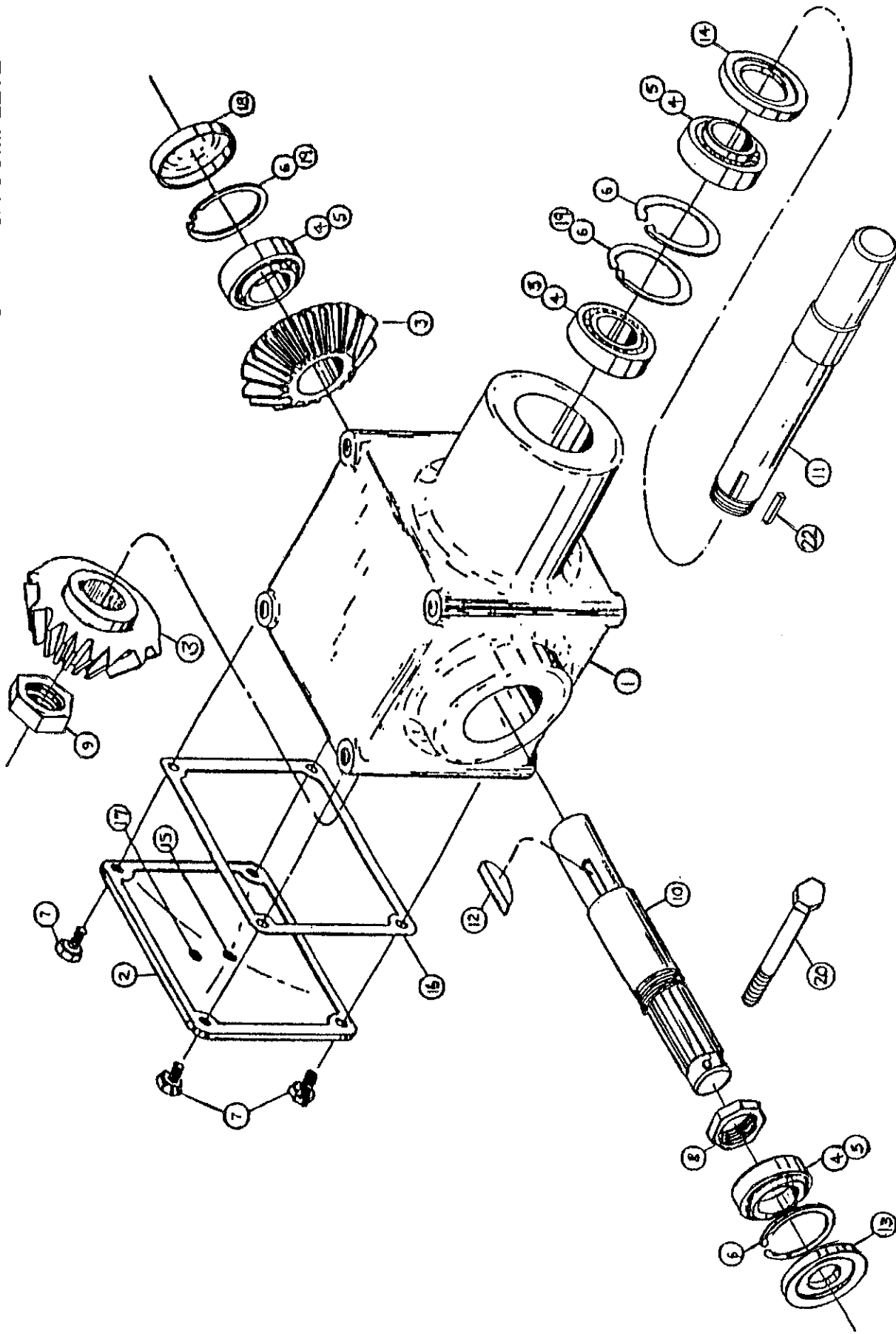
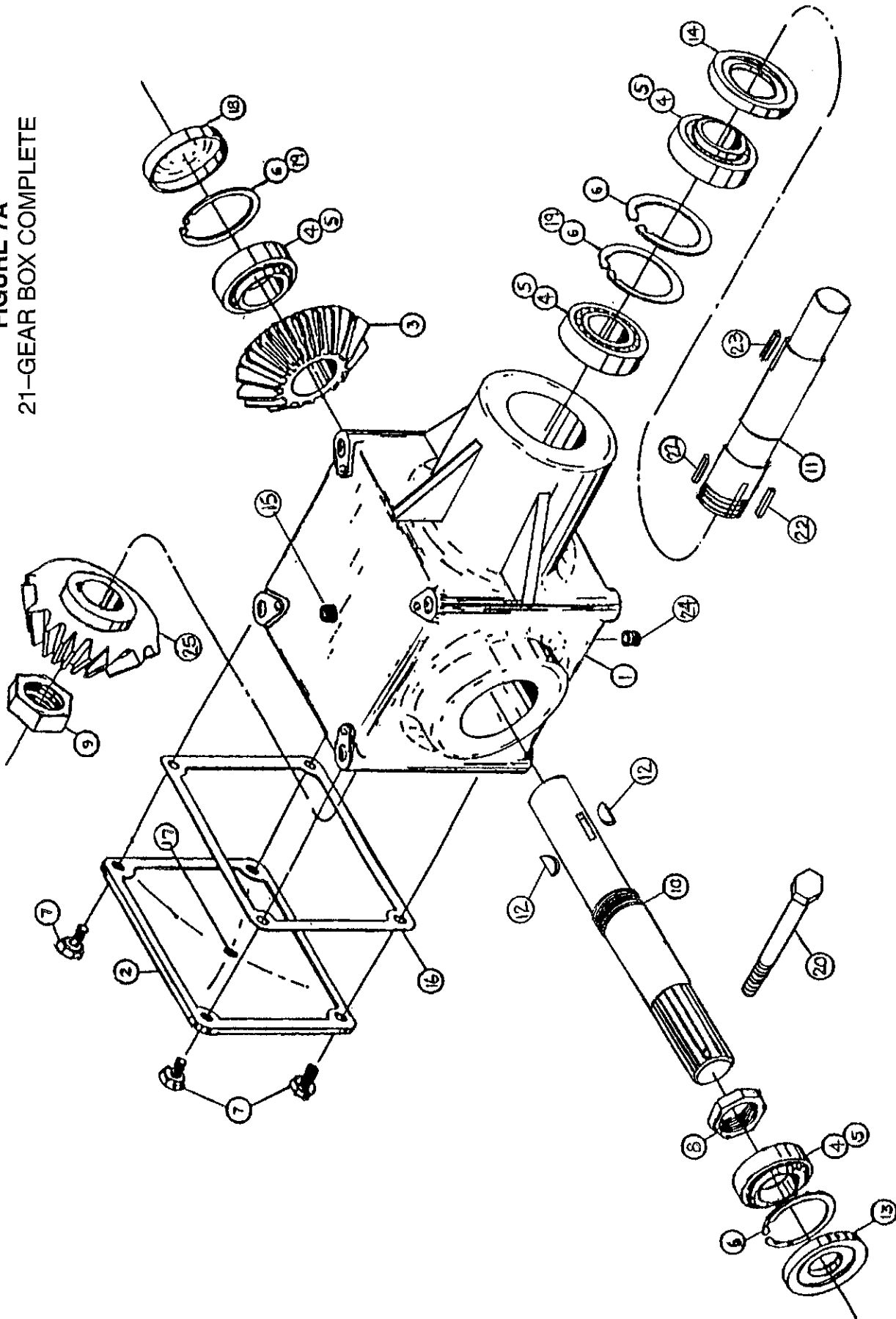

FIGURE 7
GEARBOX - INSIDE BEATER

ITEM	SPREADER SIZES		DESCRIPTION
	1506	1806	
1.	G50	"	Housing
2.	G51	"	Cover
3.	G52	"	Gear
4.	G53	"	Bearing #14137A
5.	G54	"	Bearing Cup #14276
6.	G55	"	Snap Ring
7.	G56	"	Capscrew
8.	G57	"	1-1/2" Stake Nut
9.	G58	"	1-3/8" Stake Nut
10.	16SV153	"	Output Shaft
11.	16SV154	"	Input Shaft
12.	G61	"	"E" (1210) Woodruff Key
13.	G63	"	Seal - Output
14.	G64	"	Seal - Input
15.	G65	"	Plug 3/8" NPT
16.	G66	"	Gasket
17.	G67	"	Plug 1/8" NPT
18.	G68	"	Cap
19.	G69	"	Shim
20.	23N1	"	5/16" x 5" Bolt GR.5
21.	16SV155	"	Bevel Gearbox Complete
22.	G62	"	Key 3/8" Sq. x 1-3/8" Hardened

NOTE: " (Means Same as Preceding Number)

FIGURE 7A
21-GEAR BOX COMPLETE



**FIGURE 7A
GEARBOX - INSIDE BEATER**

ITEM	SPREADER SIZES			DESCRIPTION
	2206	2606	3306	
1.	G125	"	"	Housing
2.	G126	"	"	Cover
3.	G147	"	"	Gear
4.	G129	"	"	Bearing #14137A
5.	G128	"	"	Bearing Cup #14276
6.	G130	"	"	Snap Ring
7.	G56	"	"	Capscrew
8.	G132	"	"	1-1/2" Stake Nut
9.	G133	"	"	1-3/8" Stake Nut
10.	G148	"	"	Output Shaft
11.	G149	"	"	Input Shaft
12.	G61	"	"	"E" (1210) Woodruff Key
13.	G136	"	"	Seal - Output
14.	G137	"	"	Seal - Input
15.	G144	"	"	Plug 3/8" NPT
16.	G138	"	"	Gasket
17.	G67	"	"	Plug 1/8" NPT
18.	G140	"	"	Cap
19.	G141	"	"	Shim
20.	23N1	"	"	5/16" x 5" Bolt GR.5
21.	33SV78	"	"	Bevel Gearbox Complete
22.	G139	"	"	3/8" Sq. x 1-1/2" Square Key (Hardened)
23.	16SV350	"	"	3/8" Sq. x 2" Square Key W/Round Ends
24.	G65	"	"	3/8" NPT Plug
25.	G147	"	"	Gear

NOTE: " (Means Same as Preceding Number)

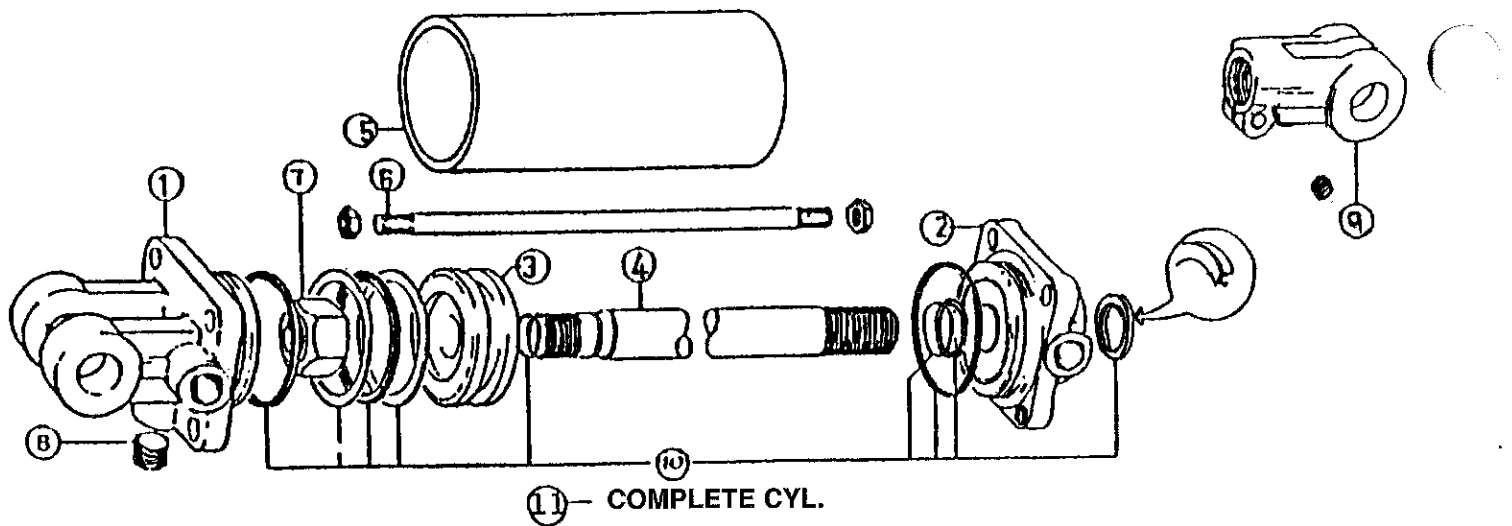
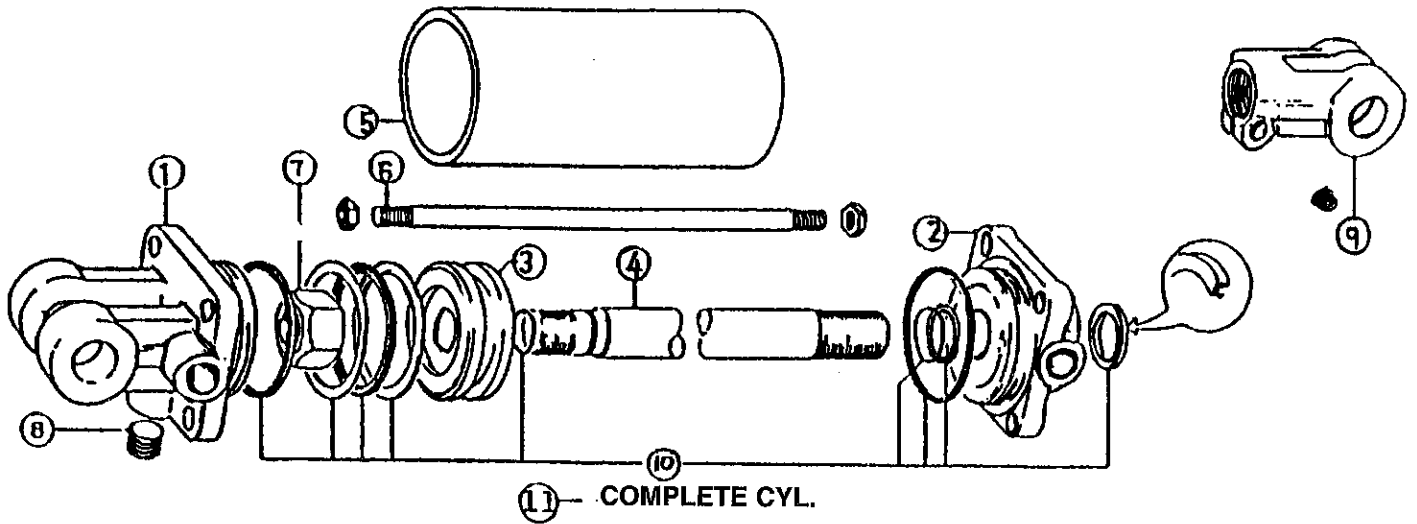

FIGURE 8
HYDRAULIC CYLINDER - BACK DOOR

SPREADER SIZES

ITEM	1502	1802	2202	2602	3302	DESCRIPTION
1.	16SV157A	"	"	"	"	Clevis Cap
2.	16SV158A	"	"	"	"	Rod Cap
3.	16SV159	"	"	"	"	Piston
4.	16SV160A	"	"	"	"	Rod
5.	16SV161	"	"	"	"	Cylinder Tube
6.	16SV162	"	"	"	"	Tie Rod
7.	16SV163	"	"	"	"	Piston Nut
8.	16SV164	"	"	"	"	Plug
9.	16SV165A	"	"	"	"	Rod Clevis
10.	16SV166	"	"	"	"	Seal Kit
11.	16SV167A	"	"	"	"	Complete Hydraulic Cylinder

NOTE: " (Means Same as Preceding Number)



**FIGURE 9
HYDRAULIC CYLINDER - CLEAN OUT DOOR**

ITEM	SPREADER SIZES					DESCRIPTION
	1502	1802	2202	2602	3302	
1.	23N142A	"	"	"	"	Clevis Cap
2.	23N143A	"	"	"	"	Rod Cap
3.	23N144	"	"	"	"	Piston
4.	16SV168A	"	"	"	"	Rod
5.	16SV169	"	"	"	"	Cylinder Tube
6.	16SV170	"	"	"	"	Tie Rod
7.	23N148	"	"	"	"	Piston Nut
8.	23N149	"	"	"	"	Plug
9.	23N150A	"	"	"	"	Rod Clevis
10.	23N151	"	"	"	"	Seal Kit
11.	16SV171A	"	"	"	"	Complete Hydraulic Cylinder

NOTE: " (Means Same as Preceding Number)

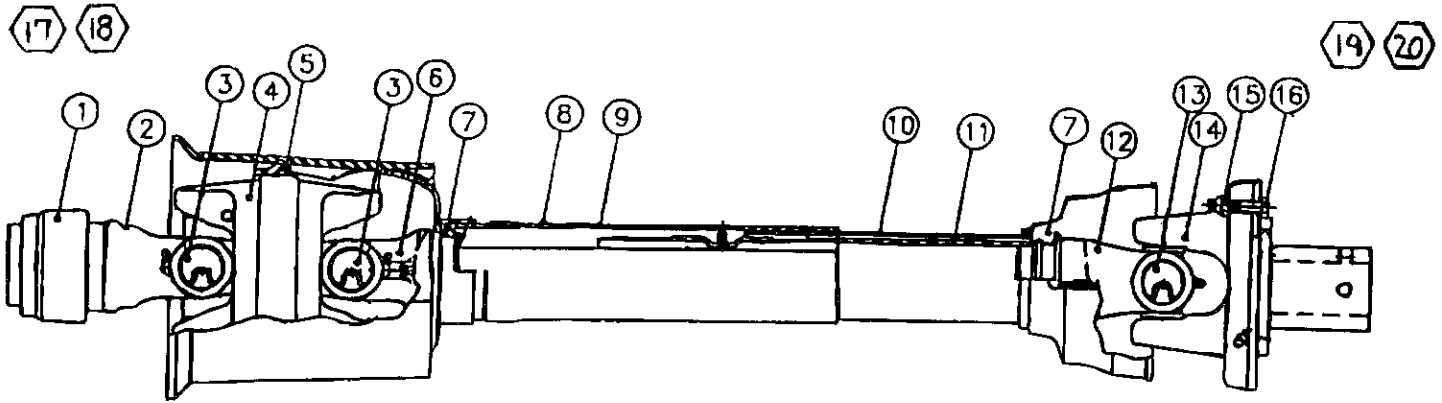

FIGURE 10
PTO

ITEM	540RPM	1000RPM-1-3/8"	1000RPM-1-3/4"	DESCRIPTION
1.	16SV274	"	16SV275	Safety Slide Lock Repair Kit
2.	16SV276	16SV277	16SV278	Safety Slide Lock Yoke Assembly
3.	16SV279	"	"	Cross & Bearing Kit (CAT. 4)
4.	16SV280	"	"	Center Housing
5.	16SV281	"	"	Bell Ext. w/Nylon Centralizer
6.	16SV282	"	"	Yoke & Shaft
7.	16SV181	"	"	Nylon Repair Kit
8.	16SV283	"	"	Safety Sign
9.	16SV284	"	"	Outer Guard
10.	16SV285	"	"	Inner Guard
11.	16SV286	"	"	Safety Sign
12.	16SV287	"	"	Yoke, Tube & Slip Sleeve
13.	16SV179	"	"	35R Cross & Bearing Kit
14.	16SV288	"	"	Ball Shear Assembly
15.	16SV194	"	"	Lock Nut 5/16"-18
16.	-	16SV289	"	Bolt 5/16"-18 x 1-1/2" GR.2
*	16SV290	-	-	Bolt 5/16"-18 x 1-1/2" GR.8
17.	16SV291	16SV292	16SV293	Joint & Shaft Half Assm. w/Guard
18.	16SV294	16SV295	16SV296	Joint & Shaft Half Assm.
19.	16SV297	16SV298	"	Joint & Tube Half Assm. w/Guard
20.	16SV299	16SV300	"	Joint & Tube Half Assm.
*	16SV343	16SV344	16SV345	Complete PTO
*	S204	"	"	PTO Safety Manual

NOTE: * (Means Not Shown)

" (Means Same as Preceding Number)

- (Means Not Used on This Model)

This PTO is for 2004 Model Year and Prior

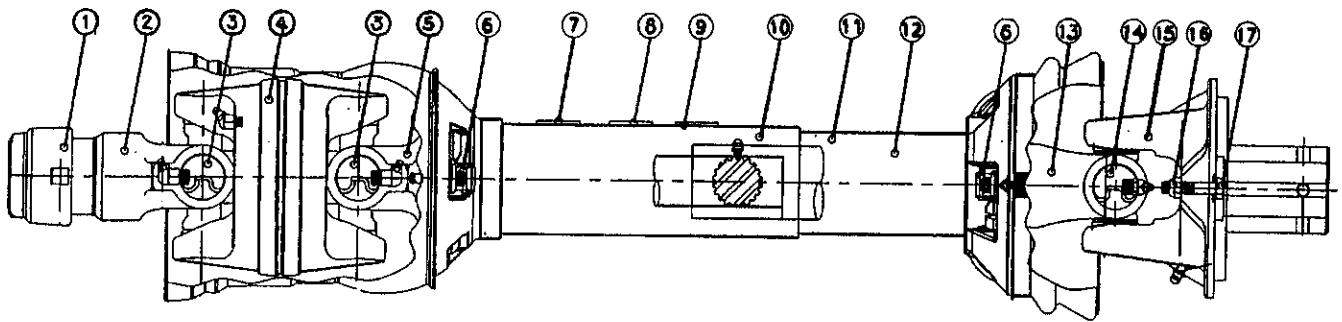
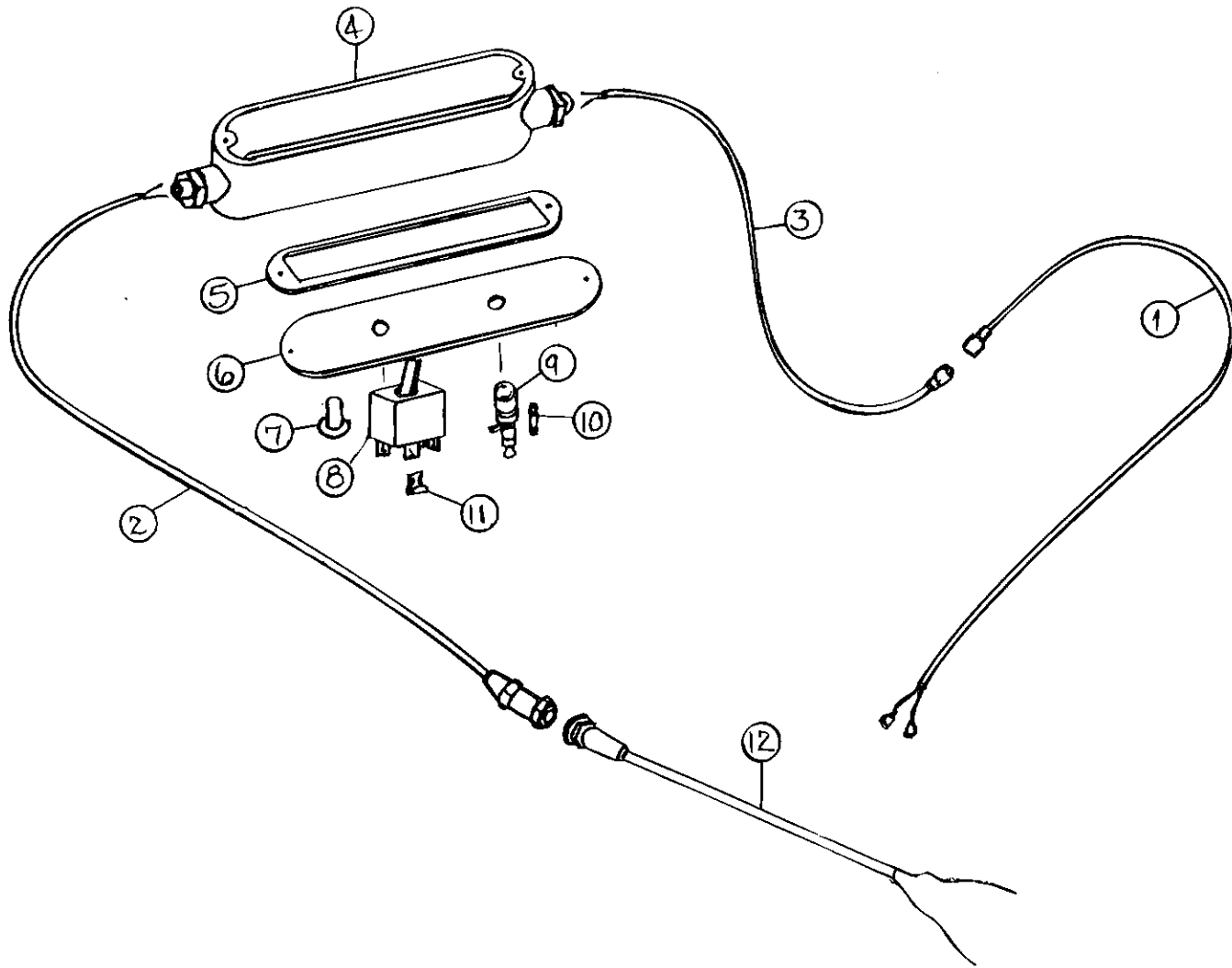

FIGURE 11
PTO

ITEM	OPT. 540RP	1000RPM-1-3/8"	1000RPM-1-3/4"	DESCRIPTION
1.	16SV274	"	16SV275	Safety Slide Lock Repair Kit
2.	16SV276	16SV277	16SV278	Safety Slide Lock Yoke Assembly
3.	16SV279	"	"	Cross Kit
4.	16SV382	"	"	Center Housing
5.	16SV282	"	"	Yoke & Shaft
6.	16SV383	"	"	Nylon Repair Kit
7.	16SV283	"	"	Safety Sign
8.	16SV286	"	"	Safety Sign
9.	16SV384	"	"	540 RPM Sign
10.	16SV385	16SV386	16SV385	Outer Guard
11.	16SV287	"	"	Inner Guard
12.	16SV388	"	"	Safety Sign (Not Shown)
13.	16SV287	"	"	Yoke, Tube & Slip Sleeve
14.	16SV179	"	"	35R Cross & Bearing Kit
15.	16SV288	"	"	Ball Shear Assembly
16.	16SV193	"	"	Lock Nut 5/16"-18
17.	16SV290	-	-	Bolt 5/16"-18 x 1-1/2" GR.8
*	-	16SV289	"	Bolt 5/16"-18 x 1-1/2" GR.2
18.	16SV389	16SV390	16SV391	Joint & Shaft Half Assm. w/Guard
19.	16SV392	16SV393	16SV394	Joint & Shaft Half Assm.
20.	16SV395	16SV396	16SV397	Joint & Tube Half Assm. w/Guard
21.	16SV299	16SV300	"	Joint & Tube Half Assm.
*	16SV343A	16SV344A	16SV345A	Complete PTO

NOTE: * (Means Not Shown)
 " (Means Same as Preceding Number)
 - (Means Not Used on This Model)

This PTO is for 2005 Model Year and After



**FIGURE 12
ELECTRIC CONTROL BOX**

ITEM	PART NO.	DESCRIPTION
1.	16SV272	Spreader Power Supply Cord w/Ends
2.	16SV271	Control Box Power Supply w/Plug in Slots
3.	16SV270	Tractor Power Supply w/Pins
4.	16SV316	Control Box
5.	16SV317	Control Box Gasket
6.	16SV318	Control Box Cover
7.	16SV235	Switch Boot
8.	16SV319	Auger Speed Switch
9.	16SV231	Fuse Holder
10.	16SV232	Fuse
11.	16SV320	Flag
12.	16SV269	Tractor Control Cord
Not Shown	16SV321	Control Box Complete

H&S ALL PURPOSE MANURE SPREADERS

Your new H&S spreader has been manufactured of the finest quality materials and components. The performance you get from your machine is largely dependent upon how well you read and understand this manual and apply this knowledge. There is a right and a wrong way to do everything. Please do not assume that you know how to operate and maintain your spreader before reading this manual carefully. Keep this manual available for ready reference.

SPECIFICATIONS

MODEL NO.	1506	1806	2206	2606	3306
Struck	200	240	292	348	441
Gallon Capacity	1502	1802	2202	2602	3302
Bu. Capacity (Old ASAE)	300	375	450	540	684
Loading Height	62"	58"	63"	69"	77"
Height w/Splashguard (Front)	69"	64"	69"	75"	77"
Overall Length	19' 7"	23' 6"	23' 6"	23' 6"	25' 8"
Inside Length	12'	16'	16'	16'	18'
Width of Tank Top	78"	78"	78"	78"	78"
Overall Width w/11x22.5	87"	91"	-	-	-
Overall Width w/16.5 x 16.1	92"	103"	103"	103"	-
Overall Width w/425 x 22.5	-	-	-	104-1/2"	104-1/2"
Weight w/Tires	5530	6870	6970	7450	8700
Axle	Single	Tandem	Tandem	Tandem	Tandem
PTO Drive	540/1000	540/1000	540/1000	540/1000	1000
Copper Bearing Steel Tank	Yes	Yes	Yes	Yes	Yes
Shear Bolt Protection	Yes	Yes	Yes	Yes	Yes
Front and Rear Splash Guards	Yes	Yes	Yes	Yes	Yes
Inside Beater	Yes	Yes	Yes	Yes	Yes
Auger Diameter	18"	18"	18"	18"	18"

NOTE

Determine right or left side of spreader by viewing it from the rear. If instructions or parts lists call for hardened bolts, they are identified with three lines or marks on the head.

H&S MANUFACTURING CO. INC.

2608 S. Hume Ave.
P.O. Box 768 - Telephone (715) 387-3414
FAX (715) 384-5463
MARSHFIELD, WI 54449



H&S WAREHOUSE Rt. #5 and 76
P.O. Box 1260 - Telephone (716) 736-7595
FAX (716) 736-7596
RIPLEY, NY 14775

H&S MFG. CO.

products approved

for the

FEMA

SEAL OF QUALITY

